

8-6-2005

## A SPATIAL DECISION SUPPORT SYSTEM UTILIZING DATA FROM THE GAP ANALYSIS PROGRAM AND A BAYESIAN BELIEF NETWORK

Jeremiah Percy Dumas

Follow this and additional works at: <https://scholarsjunction.msstate.edu/td>

---

### Recommended Citation

Dumas, Jeremiah Percy, "A SPATIAL DECISION SUPPORT SYSTEM UTILIZING DATA FROM THE GAP ANALYSIS PROGRAM AND A BAYESIAN BELIEF NETWORK" (2005). *Theses and Dissertations*. 5301. <https://scholarsjunction.msstate.edu/td/5301>

This Graduate Thesis - Open Access is brought to you for free and open access by the Theses and Dissertations at Scholars Junction. It has been accepted for inclusion in Theses and Dissertations by an authorized administrator of Scholars Junction. For more information, please contact [scholcomm@msstate.libanswers.com](mailto:scholcomm@msstate.libanswers.com).

A SPATIAL DECISION SUPPORT SYSTEM UTILIZING DATA FROM  
THE GAP ANALYSIS PROGRAM AND A BAYESIAN BELIEF  
NETWORK

By  
Jeremiah Percy Dumas

A Thesis  
Submitted to the Faculty of  
Mississippi State University  
in Partial Fulfillment of the Requirements  
for the Degree of Master of Landscape Architecture  
in the Department of Landscape Architecture

Mississippi State, Mississippi

August 2005

Name: Jeremiah Percy Dumas

Date of Degree: August 6, 2005

Institution: Mississippi State University

Major Field: Landscape Architecture

Major Professor: Wayne Wilkerson

Title of Study: A SPATIAL DECISION SUPPORT SYSTEM UTILIZING DATA FROM  
THE GAP ANALYSIS PROGRAM AND A BAYESIAN BELIEF  
NETWORK

Pages in Study: 104

Candidate for Degree of Master of Landscape Architecture

With increased degradation of natural resources due to land use decisions and the subsequent loss of biodiversity across large spatial scales, there is a need for a Spatial Decision Support System (SDSS) which showcases the impacts of developments on terrestrial and aquatic ecosystems. The Gap Analysis Program (GAP) and a Bayesian Belief Network (BBN) were used to assess the impacts of an impoundment in the Bienville National Forest, Smith County, Mississippi on landcovers, threatened and endangered species, species richness and fish populations.

A test impoundment site was chosen on Ichusa Creek and using GAP data, landcovers, species and species richness were compared with those of Bienville National Forest, Smith County, Mississippi. For the aquatic analysis, a BBN model was developed for each fish so that population probabilities could be calculated using a given configuration of available habitats and compared to current fish population.

## DEDICATION

To my greatest loves; Hope, Lawson Joy, Katherine, Phelps and Watkins this work is dedicated. To Hope, because your support, faith, encouragement, desire and strength have forever fueled me and because of them I am forever devoted. To Lawson Joy and Katherine, because your laughter lifts every mood, your hugs warm every heart and your futures are as bright as your permanent smiles. To Phelps and Watkins, because the excitement of your development and arrival emphasized the magnitude of a successful completion of this body of work.

To my parents; without your love and support, absolutely none of this would have been possible.

## ACKNOWLEDGMENTS

First and foremost I would like to thank my family for taking this ride with me and enduring any resulting neglect. Hopefully I can now enjoy time at home with a clear mind.

I want to express my gratitude to my committee members and in particular, I am extremely grateful to my major advisor, Wayne Wilkerson, for his motivation, patience, and guidance through this project. I would like to thank Hal Schramm for his patience while trying to guide me through the BBN and fisheries science, Susan Mulley for her critiques and seemingly endless knowledge and Jim Clark for his guidance throughout my studies at Mississippi State University.

Several people helped in many ways throughout this thesis and to each I am thankful. To Mel Warren and Rick Dillard of the Mississippi Forest Service for allowing me to use their fish sampling data. To Francisco Vilella and Rich Minnis for their developing the Mississippi Gap Analysis Program. To Debbie Whitfield, for all that she does. To John Cartwright for his GIS expertise, being a friend and his endless home improvements which got my mind into the real world for a change. To Ying Zhang for introducing me to “hot pot”, the year of the rooster and true Chinese culture and finally, but definitely not least, to Red Dean for being a friend and a trooper, keeping me grounded and teaching me words I never knew existed.

## LIST OF TABLES

TABLE	PAGE
3.1 GIS files information .....	18
3.2 MS-GAP data information.....	19
3.3 Fishes collected in the Leaf River and tributaries in Smith County, Mississippi by USDA Forest Service, 2002-2002.....	25
3.4 Sample locations and habitats inventoried.....	36
4.1 Smith County landcovers – acreages and percentages .....	39
4.2 Bienville National Forest, Smith County landcovers – acreages and percentages ...	40
4.3 Ichusa Creek impoundment site landcovers.....	41
4.4 Bienville National Forest and Ichusa Creek impoundment site landcovers and Percentages .....	42
4.5 Threatened and endangered species .....	43
4.6 Probabilities of habitat occurrence .....	48
4.7 General fish BBN model population probabilities .....	51
4.8 Riverine fish BBN model population probabilities .....	55
4.9 Backwater fish BBN model population probabilities.....	59

## LIST OF FIGURES

FIGURE	PAGE
1.1 Mississippi and Smith County.....	2
1.2 Smith County .....	3
2.1 Netica BBN model.....	11
3.1 Hypothetical Ichusa Creek impoundment location.....	18
3.2 Smith County DEM, LandsAT image and subsequent landcover.....	20
3.3 Smith County landcover and species richness.....	21
3.4 Leaf River sample locations .....	28
3.5 Generic BBN template .....	31
3.6 Leaf River system baseline BBN model.....	33
3.7 Ichusa Creek impoundment BBN model .....	34
3.8 Ichusa Creek 200 meter sample locations.....	35
4.1 Smith County landcovers and acreages .....	39
4.2 Bienville National Forest, Smith County landcovers .....	40
4.3 Ichusa Creek impoundment site landcovers.....	41
4.4 Study area species numbers.....	44
4.5 Bienville National Forest species richness .....	46
4.6 Hypothetical impoundment site species richness .....	46

FIGURE	PAGE
4.7 Study area mean species richness .....	47
4.8 Creek chubsucker (general habitat partition, abundant abundance) BBN models .....	52
4.9 Black madtom (general habitat partition, common abundance) BBN models .....	53
4.10 Dusky darter (general habitat partition, rare abundance) BBN models .....	54
4.11 Clear chub (riverine habitat partition, abundant abundance) BBN models .....	56
4.12 Silverjaw minnow (riverine habitat partition, common abundance) BBN models .....	57
4.13 Brighteye darter (riverine habitat partition, rare abundance) BBN models .....	58
4.14 Bluegill (backwater habitat partition, abundant abundance) BBN models .....	60
4.15 Black bullhead (backwater habitat partition, common abundance) BBN models .....	61
4.16 White crappie (backwater habitat partition, rare abundance) BBN models .....	62
5.1 SDSS flowchart .....	65
5.2 GIS flowchart .....	67
5.3 BBN flowchart .....	69
5.4 GAP flowchart .....	71
6.1 Smith County, Upper Leaf River watershed, Ichusa Lake and other potential developments .....	77



# CHAPTER I

## INTRODUCTION

### 1.1 - Introduction

This paper assesses the feasibility of creating a spatial decision support system (SDSS) that would integrate data from the Gap Analysis Program (GAP) and a Bayesian Belief Network (BBN) within a Geographic Information System (GIS). With increased degradation of natural resources due to land use decisions and the subsequent loss of biodiversity across large spatial scales, there is a need for an SDSS which showcases biodiversity and the population response of fish after developments. With a tool that is capable of doing these things, planners can locate areas in which not to develop and can see, with the reduction of habitats, the effects of a development on indigenous fish. Such a SDSS will give landscape planners an interface in which ecological data can be incorporated with traditional planning data sets so that natural resources can become a more integral part of the planning process.

### 1.2 – Study Area

Located in the south-central section of Mississippi (Figure 1.1), Smith County is bounded on the south by Covington and Jones counties, on the West by Rankin and Simpson counties and on the east by Jasper County. Raleigh is the county seat with other population centers being Mize, Taylorsville, Sylvarena, and Polkville. (Figure 1.2)

Bienville National Forest was established in 1934 and is composed of over 178,000 acres located in Smith, Jasper, Scott, and Newton counties. The fragmented Bienville

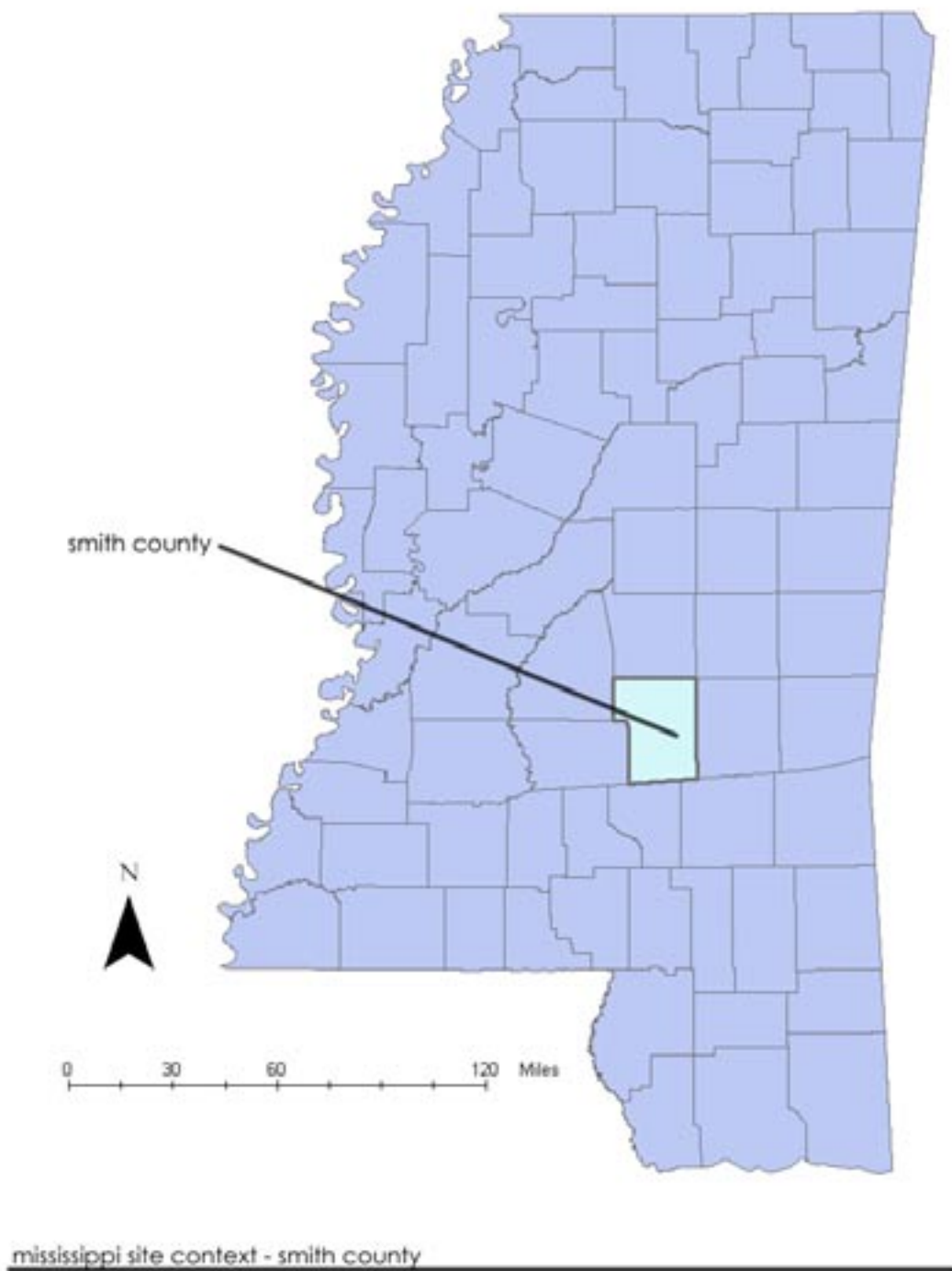


Figure 1.1. Mississippi and Smith County

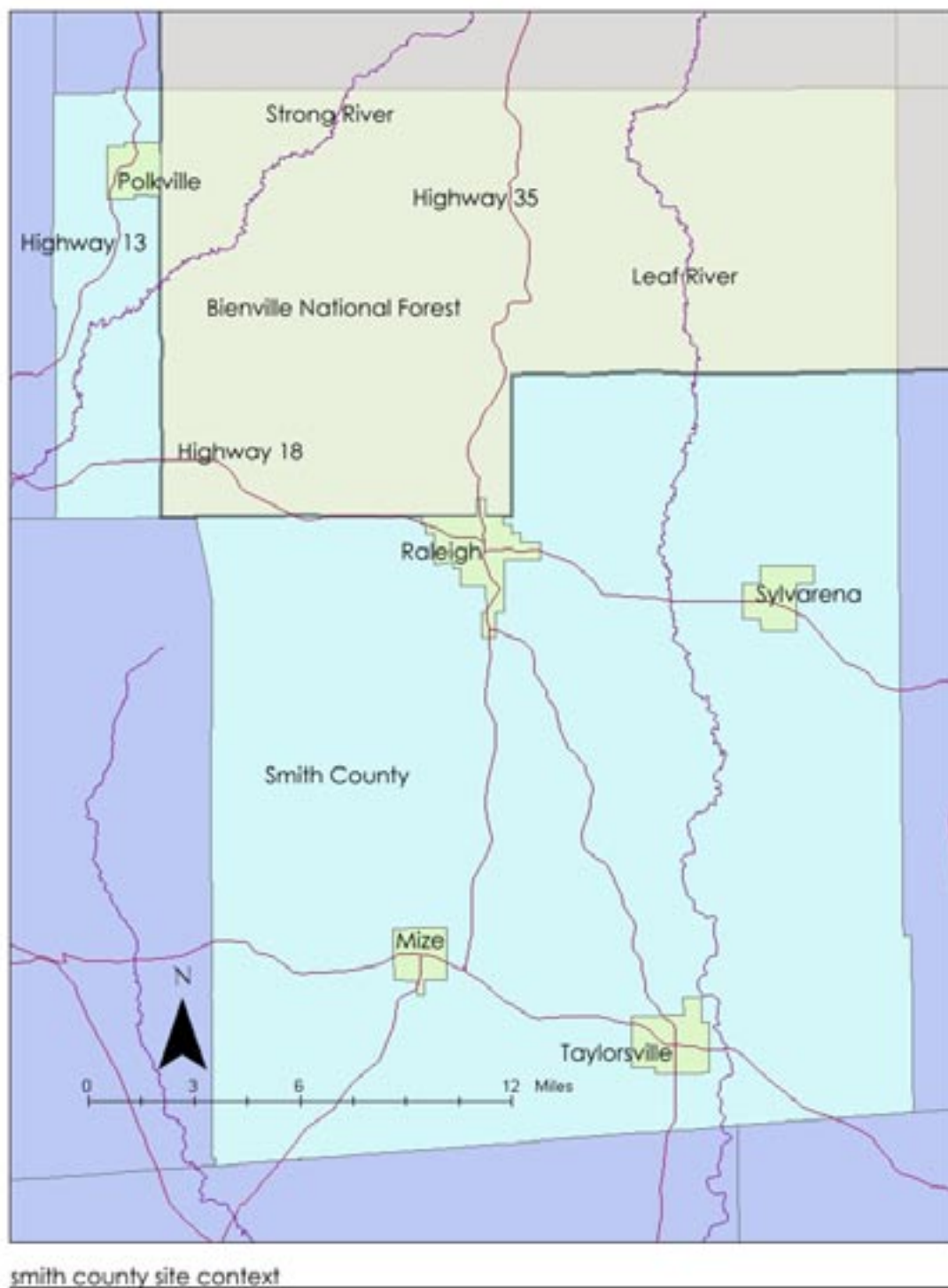


Figure 1.2. Smith County

National Forest comprises a large portion of the northeastern section of Smith County.

### **1.3 – Background**

Preliminary economic studies have recognized the benefits of a recreational water impoundment in Smith County. Historically, the tax and employment base of Smith County relied heavily on the timber industry. Environmental restrictions have curtailed the logging industry in Smith and surrounding counties. With this reduction in timber-related sales and jobs, county leaders recognized the need to develop other means of sustained income. In the 1990's county leaders met with representatives from the United States Forest Service to discuss the possibilities of constructing a multi-use/multi-purpose water impoundment.

In 2000, the Mississippi Water Resources Institute at Mississippi State was contracted by Bienville National Forest to conduct an economic feasibility study based on the construction of the water impoundment on the Bienville National Forest in Mississippi. This report, "An Economic Feasibility Study for Recreational Development on the Bienville National Forest in Mississippi" was prepared for the United States Department of Agriculture Forest Service - Southern Region by S.C. Grado, D.L. Grebner, I.A. Munn and R.O. Drier. This report was completed in 2002 and included the feasibility study and recommendations for recreational activities.

In an effort to bridge the gap between economic developers and regulatory agencies, researchers sought to develop a "tool" that could assess the impacts of this water impoundment on terrestrial and aquatic environments. This study looks at the development of such a tool using the data from the recently completed Mississippi Gap Analysis Program and a Bayesian Belief Network.

Using the Bienville National Forest in Smith County as the study site, a hypothetical impoundment location will be determined within the Leaf River system in order to test the SDSS and assess the impacts of the lake on terrestrial landcovers and vertebrates. A GIS will

also be used to quantify habitats which can be input into the BBN so that it can specifically represent species within the lake site and assess the impacts of the impoundment on current fish populations.

A SDSS, GIS, GAP, and BBN literature review is covered in Chapter 2. The methodology associated with the development of the SDSS is in Chapter 3. The results from the Bienville National Forest test site are shown in Chapter 4. The step-by-step process for using this SDSS is provided in Chapter 5 and a summary, the limitations and assumptions, and plans for future research are covered in the concluding chapter.

## CHAPTER II

### LITERATURE REVIEW

#### 2.1 – Introduction

The literature review briefly looks at the evolution of landscape planning and its impacts on the development of geographic information systems (GIS), existing research pertaining to the development of Spatial Decision Support Systems (SDSS) incorporating Bayesian Belief Networks (BBN) and the Gap Analysis Program (GAP).

The expansion of GIS technology can be traced back to the 1960s, and is directly related to enhancements in desktop personal computers. It has become a universally accepted computer software system that has the capability of handling spatially explicit data. This computer revolution has broadened the magnitude and efficiency of landscape planning and provides the ability to incorporate multiple and diverse types of data.

The term landscape refers to the interface between humans and natural systems whereas landscape planning refers to a change in the landscape to more closely tie society to nature in an ecologically responsible manner (Ndubisi 1997). For landscape architects, landscape planning dates back to the mid-nineteenth century, with Frederick Law Olmstead's plan for Yosemite Valley, which not only proposed landscape development but management and conservation of areas of natural beauty (Ndubisi 1997). Charles Eliot, an Olmstead protégé, developed the first urban park system that included recreation, the preservation of natural areas, and the management of water quality (Ndubisi 1997). Landscape planning standards have helped guide the designs of other important national parks and recreation areas in the late nineteenth and early twentieth centuries such as

Yosemite National Park, Bronx River Park, and the Grand Canyon National Park.

Another important landscape architect/planner in the mid twentieth century was Ian McHarg. In his *Design with Nature* (1969), McHarg spelled out an approach for planning based on sensitivity to ecological and natural systems. At the time this theory was developed the basic tools used by planners and designers were still hand based. Most of his initial studies were created using pen, paper, and a light table. These tools were soon replaced by computers running the first rudimentary GIS applications. Today's GISs easily accomplish the same analytical tasks in a much shorter time frame as well as interface with other spatial and non-spatial systems. It is for these reasons that a GIS will be used for the integration of the BBN and GAP data sets.

## 2.2 - Geographic Information Systems

Management issues containing spatial components mesh well with GIS technology due to their standard sets of commands that aid in routine operations such as overlay, buffering, attribute selection, and digitizing (Mugglin and Carlin 1999, Skidmore 1996). GISs have multiple applications that can facilitate and process diverse data; and, thanks to the recent advent of the Internet, endless amounts of geographical data and models are now available for download (Sengupta 2002). This has dramatically altered the ability of researchers, regulatory agencies, planners, and consultants to exchange vast amounts of information in a framework in which diverse data types can be incorporated (Dymond 2004).

From its inception, GISs have been viewed as a tool box of commands for input, analysis, storage, retrieval, and display of spatial data. Currently, there is a clear need for combining the data handling "toolbox" of a GIS and the specific analytical functions needed to address problems in an easy to develop and operate software (Tomlin 1987, Makropoulos 2003). In areas such as landscape planning, where decisions are made about issues with complex physical and social implications within complex organizational frameworks, a

GIS presents the user with an interface that provides a means for analysis and also enables specification of decision scenarios and presentation. It is this interface and analytical ability that offers the best solution for the integration of diverse data types and models, such as BBN and GAP (Taylor 1999).

### **2.3 - Spatial Decision Support System**

Spatial decision support systems (SDSS) are designed to utilize the graphical display of a GIS to manage complex resource problems and to support the design and evaluation of plans (Aerts et al. 2003). The overriding goal of an SDSS is to assist decision makers as they methodically develop solutions to diverse geographical problems, and to analyze these solutions using applicable data and models (Sengupta and Bennett 2003).

Decision-makers often lack the expertise that is necessary to efficiently run and integrate web-accessible GIS models (Davis 1996). Because of this it is imperative to streamline the process within a GIS interface that is applicable throughout multiple disciplines. In order to solve complex problems of a broad scope, the GIS interface must have the ability to access multiple models. This access is feasible by integrating multiple software packages into decision support systems offering a coherent map-based problem-oriented interface to underlying models (Taylor 1999).

Even before the evolution of modern computers and software packages, decision support systems (DSS) were recognized as valid models that aided in problem solving. Sprague (1980) states that a DSS is a system that helps managers solve problems, combine analytical models with traditional data storage and retrieval functions in a manner that is applicable even with minimal computer exposure or knowledge and flexible enough to handle diverse types of decision-making approaches.

Armstrong (1986) introduces SDSSs as systems with similar characteristics that integrate spatial data with traditional geoprocessing software. Taylor (1999) states that SDSSs



are currently recognized as important tools for planning and decision making for environmental management. A SDSS allows the operator to focus on the problem at hand, integrate diverse amounts of data, and supply modeling to address spatially explicit problems (Dymond 2004). However, most decision-makers want an SDSS that will provide them information without having to familiarize themselves with the details of the system (Nijkamp and Scholten 1993). Therefore, to produce a simplified, user-friendly SDSS, it often requires the construction of the model be done by someone possessing considerable technical knowledge (Sengupta 2002).

Due to the diversity of software that is used in an SDSS, there are various forms of coupling software within a computer framework (Sengupta 2002). The three basic forms are: loose, tight, and full (Goodchild 1992). Loose coupling refers to the type of SDSS in which spatial data are reformatted to meet the input requirements of various models; and, although these forms are flexible, users must deal with multiple interfaces and countless data formats (Goodchild 1992). Tightly coupled systems rely on wizards within the software to facilitate the processes of data conversions and to provide links to other models from within the GIS interface. While this simplifies the user interface, it greatly reduces flexibility of the system compared with the loosely coupled system (Sengupta 2002). Within the fully coupled systems, GIS and spatial models are combined within a single software package. User interaction is fairly straightforward, but like the tightly coupled system, this system lacks the flexibility needed in order to adapt to the dynamic nature of an SDSS (Sengupta 2002).

For the operator to become efficient in solving problems, it is imperative that they can adapt to each model that is integrated within the SDSS (Taylor 1999). Until recent improvements in GISs, geographically referenced data capable of handling an SDSS did not exist or was too expensive for most to acquire, and the integration of large data sets was impossible due to the limited capabilities of computers and computer operators (Sengupta 2002). As is often the case with other computer applications, the users must familiarize

themselves with the underlying processes of the integrated systems or models, because it is the users' responsibility to modify data types when needed, input data and translate results.

## 2.4 - Bayesian Belief Network

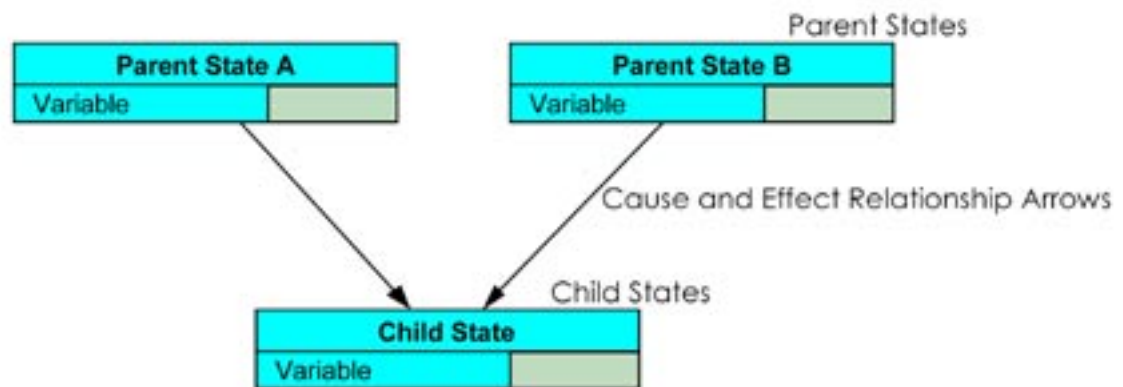
Bayesian belief networks are knowledge-based expert systems that predict the probability of an event occurring, or diagnose the most probable cause of specific problems (Sahely and Bagley 2001). BBNs are based on Bayes' Theorem, which is named after Thomas Bayes, an eighteenth century British mathematician and Presbyterian minister, who "first used probability inductively and established a mathematical basis for probability inference" (Britannica 2004).

Varis (1997) states that BBNs were originally developed as a formal means of analyzing decision strategies under uncertain conditions. "The uncertainty is accounted for by using Bayesian probability theory", previously referred to as Bayes' Theorem, "which allows subjective assessments of the chance that a particular outcome will occur to be combined with more objective data quantifying the frequency of occurrence" (Cain et al. 1999, p. 124). The operations of BBNs are somewhat complex and are often referred to as a probabilistic expert system (Spiegelhalter et al. 1993) which depends on underlying algorithms for fast probabilistic calculations, conditional on any configuration of observed data (Spiegelhalter et al. 1993).

BBNs have been used in many different fields of study: natural resource management (Cain et al. 1999, Tattari et al. 2003, Raphael et al. 2001, Rieman et al. 2001, etc.), research management (Henderson and Burn 2004), and water quality monitoring (Pike 2004, Sahely and Bagley 2001, etc.) to name a few, but have only been utilized in environmental modeling for the past several years (Cain et al. 1999). "BBNs have been developed from attempts to model complex causal relations in the face of uncertainty, with early applications being in expert systems for medical diagnosis" (Henderson and Burn 2004, p. 4). This approach was founded on a cause and effect diagram represented with boxes as variable and the interaction

between them as arrows (Cain et al. 1999).

BBNs are made up of states which consist of variables and arrows which connect related states (Figure 2.1). The arrows represent a cause and effect relationship between parent and child states. This relationship allows changes made to a variable within the parent state to directly influence the variable within the child state. “This effect is quantified by assigning a probability that a child variable will be in a particular state given the state of any parent variables” (Cain et al. 1999, p. 125). The arrow points from the parent state to the child state and variables associated with parent states are passed to the related child state. Variables from each state are probabilities and through the relationships represented by arrows, all connected parent state variables are integrated within the child state and by using Bayes Theorem child state variables are calculated. “In certain instances, these probabilities may be derived from observed data, such as the results of a survey, but more often they are subjective probabilities and choosing their values is the principal task in constructing a BBN” (Henderson and Burn 2004, p. 7). Bayes Theorem  $P(A | B) = P(A)P(B | A) / P(B)$  is nothing more than a conditional probability with P being the probability of A occurring giving B has previously occurred



**Figure 2.1.** Netica BBN model. Parent and child states, variables, and relationship arrows.

(Joyce 2003).

“The power of the BBN, however arises from its ability to recalculate the probabilities of all variables, parent and child, when evidence is introduced into the network” (Sahely and Bagley 2001, p. 303). For this study, Netica™ software will serve as the network for the BBN. Netica is an interface in which users can construct BBN models complete with state, variables, and relationships between parent and child states. Because of the embedded Bayes Theorem, Netica readily updates probabilities within child states as evidence is introduced into related parent states.

## **2.5 - Bayesian Belief Networks and Geographic Information Systems**

BBNs have been integrated with GIS's to incorporate statistical models and spatially explicit information in the same problem solving environment. A GIS is an efficient handler of spatial surveys and data. BBNs exhibit great flexibility in the analysis of spatial and non-spatial data. By integrating the two a viable tool is created that is capable of handling diverse data (Burrough 2001). For example, attributes from a GIS are input into the SDSS, which then processes the data and uses the BBN to update the probability of the rule that the hypothesis will occur at a location given a piece of evidence (Skidmore 1996).

Computer technology has changed considerably in the past decade and GISs have greatly increased the capabilities of processing and analyzing spatial data. Because of the increase in processing ability and data storage of computers and environmental issues that can now be linked to specific spatial coordinates; computers are now capable of integrating several models to produce an SDSS. With an SDSS integrating GAP and a BBN, natural resources can now become a more integral part of the planning process, thereby giving planners the ability to take into account and even predict impacts of various land use decisions on natural resources.

## 2.6 - The Gap Analysis Program

In 1976 the United States Endangered Species Act was passed to protect flora and fauna from extinction. Habitat loss or degradation is one of the biggest factors contributing to species becoming endangered or extinct, and human influences such as land use decisions and development are the primary cause for habitat or biodiversity loss. Since the passing of the Endangered Species Act, much has been done in the way of studying and protecting endangered species in hopes of preserving their existence. As populations and species extinction intensifies, spatial biogeographic information of the appropriate resolution is vital for the management and preservation of our biological resources (Jennings 2000).

Until the late twentieth century, very little had been done to protect commonly occurring native species and their habitats. This neglect of common species and habitats allowed for continued habitat and biodiversity loss, which, in turn, expanded the Endangered Species list with once common flora and fauna. The Endangered Species Act encourages species-specific management, but Noss (1987) recognized the need for landscape-scale management to conserve biodiversity in the aggregate. The species-specific approach has been successful in helping to protect endangered species, but has done little in the way of conserving common, native species.

Advances with GISs and remote sensing have given natural resource managers, conservation biologists and other professionals the ability to utilize coarse-filter approaches to manage research and view biodiversity at landscape scales. Two filter types have been put to use by agencies such as The Nature Conservancy for the inventory and evaluation of elements of biodiversity (Noss 1987). Coarse-filter refers to a sampling or inventory approach across community or landscape scales. It is the scale of filter in which broad ranging or highly populated species are inventoried and it has been found that 85-90% of species can be accounted for using a coarse filter. The 85-90% consists of commonly occurring species with widespread range and distribution. A fine filter, used for species scale inventories, is used

for the remaining 10-15% of species, usually rare, threatened or endangered species (Noss 1987).

Before the Gap Analysis Program (GAP) began mapping land cover at resolutions meaningful to the management of biodiversity, there was no standard landscape-level spatial data available, even in the way of landcover maps (Jennings and Scott 1997). With increased access to GIS technology, advances in computers, and the launching of Landsat satellites, remotely sensed imagery can be produced at a scale that enables a coarse-filter approach to biodiversity management and conservation.

Gap analysis was developed as a proactive coarse-filter approach to protecting biodiversity, with an original intent of a “quick overview of the distribution and conservation status of several components of biodiversity” (Scott et al. 1993, p. 785). “Gap analysis is a scientific method for identifying the degree to which native animal species and natural communities are represented in our present-day mix of conservation lands” (Jennings and Scott 1997, p. 2). Hence, flora and fauna not existing in conservation lands constitute conservation “gaps”.

The development of methods for gap analysis began in 1987 in response to the need to complement species-by-species management in dealing with broad spectrum habitat loss (Scott et al. 1987). There was a need for spatially explicit information for vertebrate species, plant communities and their management status (Scott et al. 1987). With the advent of computer-interfaced GISs, problems with mapping biodiversity have been reduced; and today numerous tools that utilize spatial data are available. Gap analysis provides an overview of terrestrial vertebrates and land cover types relative to land stewardship or conservation areas. This layering of terrestrial vertebrates and land cover types allow for the computation of spatially explicit species richness (Jennings 2000).

While Jennings and Scott (1997) state that the mission of GAP is to provide state, regional, and national assessments of the conservation status of native vertebrate species

and natural land cover types of the United States and to facilitate the application of this information to land management activities, they make it clear that gap analysis is not a substitute for intensive localized inventories, nor a replacement for traditional single-species approaches to protecting biodiversity. GAP allows for a quick display of data that can be used to identify opportunities for future resource conflicts (Jennings and Scott 1997).

Gap data sets are produced at a nominal scale of 1:100,000 and in most cases this translates to a 30 square meter map unit (Jennings and Scott 1997). The maps and data layers are produced using similar but varying techniques. For land cover maps, a contiguous vegetation classification was adopted, based on the National Vegetation Classification (NVC) (Jennings 2000). The acquisition of the digital data is the next step, beginning with imagery and including but not limited to, digital elevation models, soil maps, vegetation maps, field reconnaissance data, and the National Wetlands Inventory (Jennings 2000). For land cover maps, areas of homogeneity are delineated and, by utilizing the NVC, are classified. Lastly, an assessment of overall accuracy of the landcover is conducted (Jennings 2000). This accuracy assessment is accomplished by a three-step process in which independent (reference) data are acquired and used to assess accuracy (Jennings 2000). Reference data should consist of point samples gathered either on the ground or remotely sensed using aerial photography.

Vertebrate maps are constructed in a more complex manner. These maps are “predictions about the occurrence of a species within a particular area” (Csuti and Crist 1998). Like the land cover process, a species list should be determined, either utilizing the Integrated Taxonomic Information System or the National Heritage Central Database (Jennings 2000). Local records of each species should then be obtained, and the extent of each species range is delineated into units of known occurrences (Jennings 2000). After conducting a literature review of each species, a habitat association for each species is developed so that a species-habitat relationship matrix can be developed. With the GIS species-habitat matrix, a species-habitat map is reviewed and developed. These data are then also assessed for accuracy

(Jennings 2000).

Land stewardship maps show all lands within the state and their management regime. These lands are grouped within four management or stewardship types: Status 1: lands permanently protected from conversion of natural land with a mandated management plan within which natural disturbance events occur, Status 2: lands permanently protected from conversion of natural land with a mandated management plan within which uses or management practices may occur that degrade existing natural communities, Status 3: lands having permanent protection from conversion of natural land for the majority of the area within which extractive uses can occur, Status 4: lands lacking a mandated management plan to prevent conversion of natural habitat types to anthropogenic types.

The Mississippi Gap Analysis Program (MS-GAP) is coordinated by the U.S. Geological Survey Mississippi Cooperative Fish and Wildlife Research Unit. Beginning in 1994, MS-GAP began the process of refining vegetation maps for the state with a minimum mapping unit, an area of ground coverage per digital map pixel, of two hectares. The land cover maps, which were produced by the Spatial Information Technologies Laboratory of the Forest and Wildlife Research Center, identified 51 different classes of forest and other vegetation types (Vilella and Minnis 1997). Using expert knowledge, the modeling process of GAP analysis determines vertebrate distribution based on land cover types to predict the species that exist over large scales. Aspects including landcover, vertebrate distribution, and land stewardship, are each contained within individual GIS layers. The data are public domain and available through the Cooperative Fish and Wildlife Research Unit at Mississippi State University.

Crist (2000) states that land use planners are not land managers, because once land uses are approved, there is no management other than to police the prescribed use. Appropriate land use planning is essential to the conservation of biodiversity. Gap analysis, when applied at the forefront of the planning process, can aid design by locating hotspots of biodiversity and help deter developments from impinging on vital areas of biodiversity wealth.



## CHAPTER III

### METHODS

#### 3.1 – Introduction

This chapter is divided into three sections: GIS, GAP, and BBN. GIS and GAP pertains to the data and tools used within each and BBN pertains to the data and running of the BBN models.

This spatial decision support system (SDSS) will be used to assess the impacts of a water impoundment on terrestrial and aquatic ecosystems. A BBN model was developed to assess the probable impact of the impoundment on aquatic species, and GAP data were analyzed for terrestrial impacts and the impoundment site digitized using ESRI ArcGIS™.

#### 3.2 – GIS

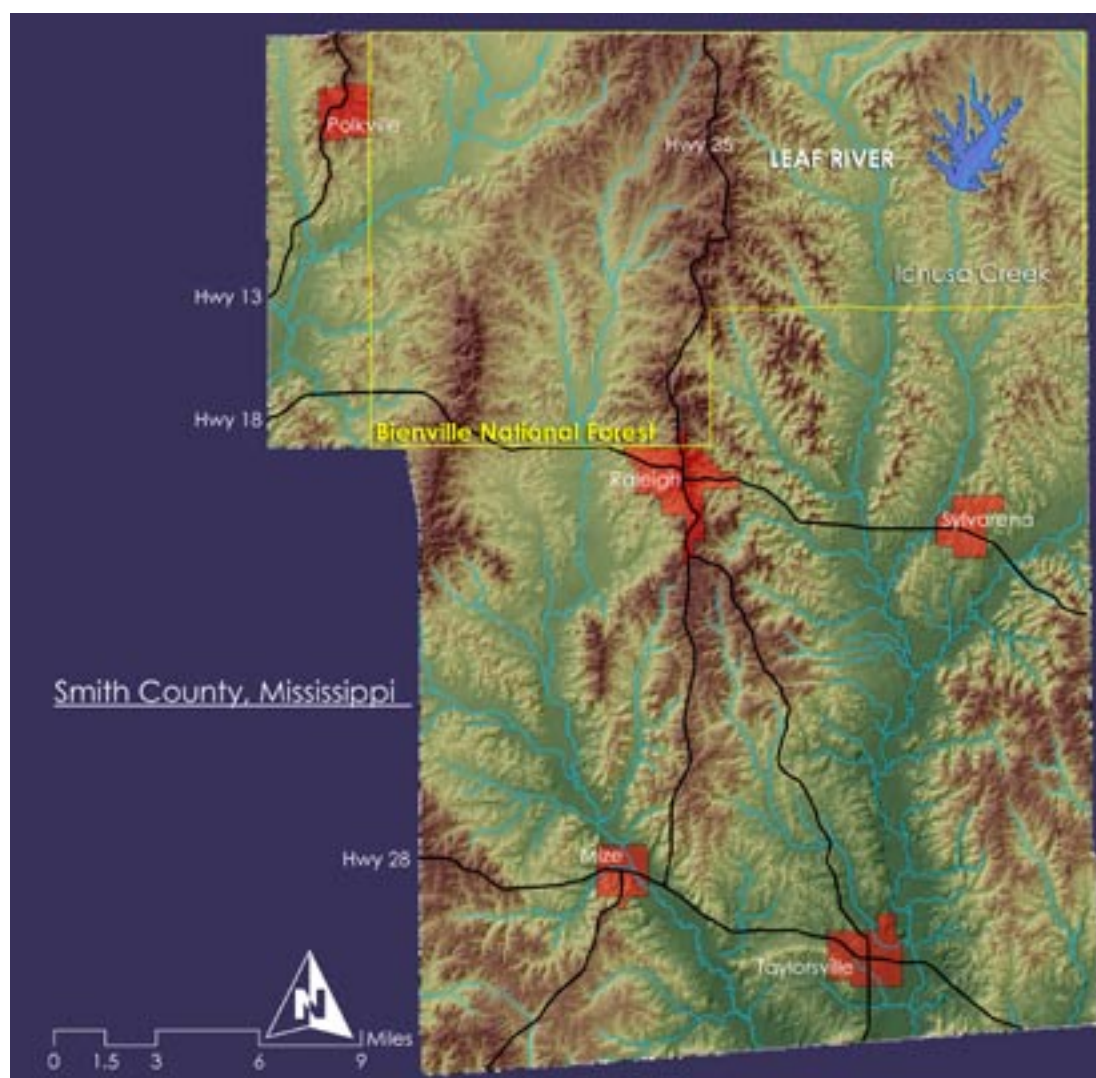
GIS data that were used in this model included data acquired from the Mississippi Automated Resource Information System (MARIS), such as digital orthophotographies (DOQQ's) and the Mississippi National Forest Boundary theme file (Table 3.1). Each data type was imported into ERDAS Imagine™ and subset using the Smith County, Mississippi boundary.

For demonstration purposes a hypothetical impoundment site was randomly selected within the Bienville National Forest, Smith County Leaf River system and digitized using ArcGIS 8.3™. The impoundment is located on the headwaters of Ichusa Creek with a surface elevation of 400 ft. mean sea level (MSL) and the impoundment's

control structure is located 3.75 miles below the headwaters of Ichusa Creek (Figure 3.1).

**Table 3.1.** GIS files information

<u>File</u>	<u>Source</u>	<u>Content</u>	<u>Format</u>	<u>Scale</u>	<u>Date</u>
DOQQ's	MARIS	Aerial Images	SID	N/A	Jan-96
National forest	MARIS	MS National Forest	Shapefile	1:100,000	N/A



**Figure 3.1.** Hypothetical Ichusa Creek impoundment location

### 3.3 – GAP

All Mississippi GAP data are public domain and obtainable from the Mississippi Gap Analysis Program (MS-GAP) (Table 3.2). GAP is composed of multiple GIS data layers, all listed under the folders of landcover, vertebrates, stewardship, and ancillary. The landcover data layer is gleaned from a remotely sensed geo-rectified satellite image of the state of Mississippi that has been coded using the National Vegetation Classification. Figure 3.2 shows the digital elevation model (DEM), LandSAT, and subsequent landcover map. For vertebrates, layers exist for each species of birds, herpetiles, and mammals that display places of known occurrences throughout Mississippi. Data layers also exist which show species richness for birds, mammals and herpetiles (Figure 3.3). The stewardship layer consists of data showing level of protection based on land management practices described in Chapter II. Ancillary data consist of Mississippi quadrangle, townships, and counties shapefiles (Vilella and Minnis 1997) (Table 3.2).

**Table 3.2.** MS-GAP data information

<u>File</u>	<u>Source</u>	<u>Content</u>	<u>Format</u>	<u>Scale</u>	<u>Date</u>
landcover	MS-GAP	Landcover Species Richness	ESRI ArcMAP Document	1:100,000	Jan-98
mammals	MS-GAP	Mammalian Species Richness	ESRI ArcMAP Document	1:100,000	N/A
birds	MS-GAP	Bird Species Richness	ESRI ArcMAP Document	1:100,000	N/A
herpetiles	MS-GAP	Herpetiles Species Richness	ESRI ArcMAP Document	1:100,000	N/A
stewardship	MS-GAP	Mississippi Stewardship Map	ESRI ArcMAP Document	1:100,000	Oct-03
msquad	MS-GAP	MS Quads	ESRI ArcMAP Document	1:100,000	N/A
townships	MS-GAP	MS Townships	ESRI ArcMAP Document	1:100,000	N/A
counties	MS-GAP	MS Counties	ESRI ArcMAP Document	1:100,000	N/A

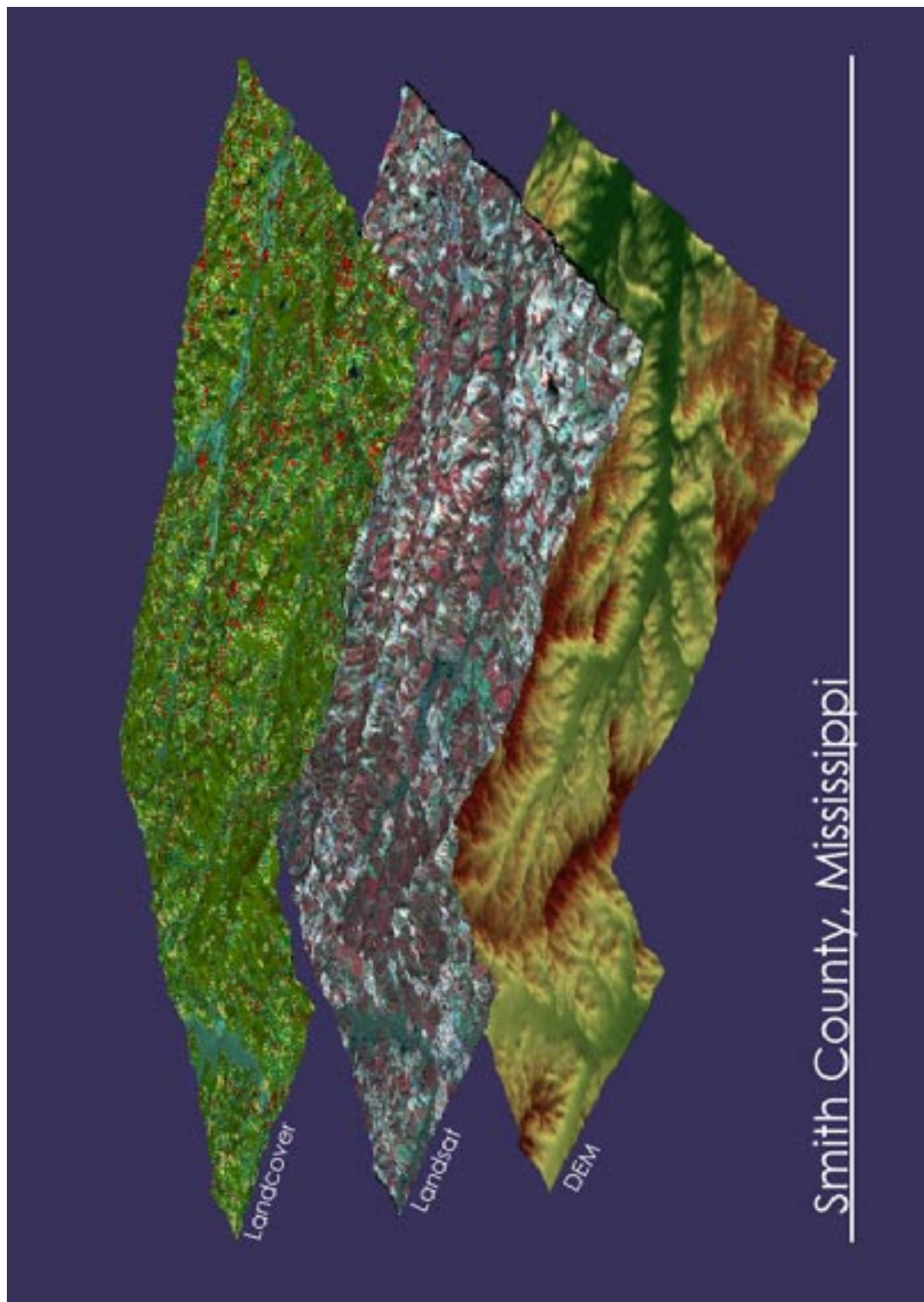


Figure 3.2. Smith County digital elevation model, LandsAT image and subsequent landcover.



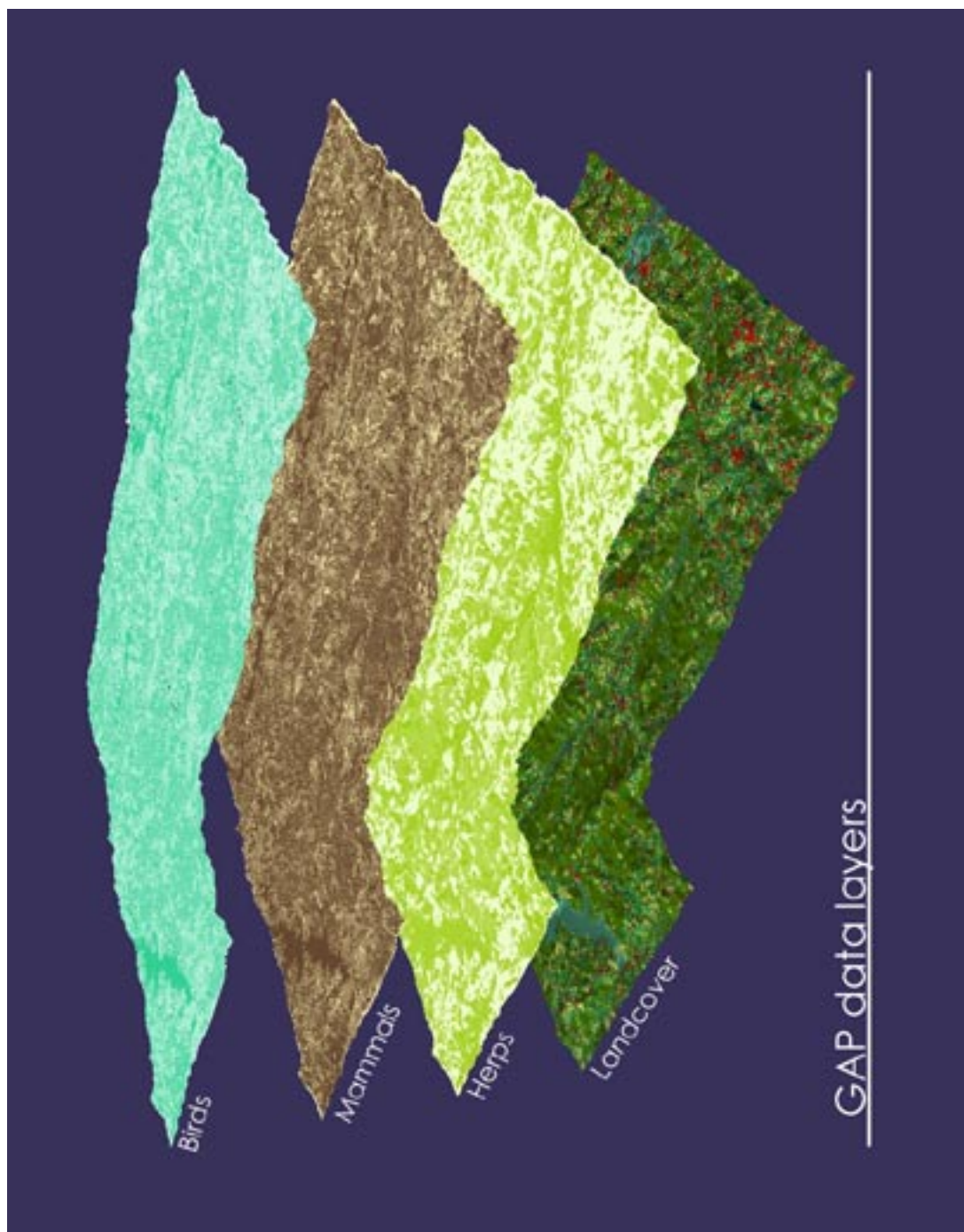


Figure 3.3. Smith County landcover and species richness.

All MS-GAP data were first subset to Smith County, then to Bienville National Forest, and finally to the Ichusa Creek impoundment site. For each subset, landcovers and species richness were quantified. The ArcGIS landcover attribute table provided the landcover type and a pixel count for each and knowing that each pixel is 30 square meters, it is possible to calculate acreage totals per landcover type.

In order to assess the impact of this impoundment on different landcover types two comparisons were performed. The MS-GAP landcovers affected by the development of the impoundment were calculated as a percentage of the overall Bienville National Forest landcovers and likewise with the National Forest and county landcovers. The same assessment was performed at the National Forest/county scale in order to understand the percentage of landcover lost at a county scale.

Species richness was subset in the same manner as the landcover. However, attribute tables associated with species richness maps provide both value (the actual species richness number, species per pixel) and count (number of pixels having that value). Often times, multiple pixels shared the same value and counts were randomly dispersed among values. Because of this a standard mean cannot accurately depict a subset's true mean species richness. It is suggested throughout statistical literature that when an individual data value represents a value that is used more than once, a weighted mean should be used (Spiegel and Stephens 1999). Therefore, a weighted mean was calculated by multiplying the species richness value by the number of times it is found, adding each value and dividing by the total pixel count.

A weighted mean was calculated for each subset of vertebrate species richness. With these counts it is possible to determine if areas high in species richness are being affected by the development.

### **3.4 – BBN**

A Bayesian Belief Network (BBN) was used to predict the effects that an impoundment

on a Leaf River tributary will have on indigenous fish. This study focuses on the Leaf River system located within the Bienville National Forest in Smith County, Mississippi. In particular, this study compares the results of a BBN model with current habitat percentages to one with habitat numbers representative of what would be available to fish after impoundment above the control structure. It was determined to only use the area above the control structure for comparison because of the potential for fish below the control structure to access habitats lower in the system, it being a controlled environment with minimal inflows from other sources, and the section of Ichusa Creek affected by the impoundment could be inventoried for aquatic habitats. The impoundment site constitutes 90% of Ichusa Creek above the control structure and the headwaters of Ichusa Creek above the impoundment are ephemeral for the majority of the year, therefore most riverine or flowing water habitats will be lost with the development of the impoundment.

The BBN model used for this study was previously developed by employees from the Mississippi USGS Fish and Wildlife Cooperative Research Unit, University of Pine Bluff Arkansas, and Arkansas Tech to work with fishes of the White River in Arkansas. Federal and university researchers developed the model to gain an understanding of population statuses for fish species given changes in habitats. The White River BBN model provided the standard methodology by which this model was built. No literature has been published regarding the White River study. The methodology for the White River Study is currently being peer reviewed.

Species present in the upper Leaf River system were based on extensive sampling by the USDA Forest Service in 2000-2002 (Table 3.3). Available information (i.e. spawning habitat requirements, favored habitats, etc.) for each species was used to determine (1) habitat use weightings for each life stage and (2) abundance probabilities. The BBN for this research project is habitat driven. Habitats available to fishes in the upper Leaf River tributaries are backwaters, floodplain lakes, riffles, runs, and pools. Habitat use was based on information

gleaned from Becker (1983), Pflieger (1975), Robinson and Buchanan (1988), and Ross (2001) and served as input for the BBN model.

For purposes of this modeling exercise, habitat and life stage terms are defined as follows:

- Floodplain lake – a permanent or ephemeral body of water connected to the river during at least a portion of most years.
- Backwater – an area of standing or slowly flowing water partially isolated from the flow of the main channel of the river but confluent with the river at least during normal flows.
- Riffle – shallow reach with relatively swiftly flowing water and often with surface turbulence at moderate to high flows.
- Run – reach with moderate depth and moderate to swiftly flowing water with no surface turbulence.
- Pools – habitat with a low gradient that is deeper and has slower current velocity than habitats immediately upstream and downstream from it.
- Spawning – conditions required for egg laying and incubation.
- Recruitment – the life stage (and time period) from post-hatching to a size and age at which they commence adult behaviors.
- Adult capacity – survival and growth of a fish exhibiting adult behaviors (e.g., diet and feeding behavior, movement, habitat selection, intra- and interspecific interactions).



**Table 3.3.** Fishes collected in the Leaf River and tributaries in Smith County, Mississippi, by USDA Forest Service, 2000-2002. Catch is the mean number of individuals collected with a standardized electrofishing effort at 12 tributary sampling sites (Figure 3.4). For abundance class see the abundance probabilities section.

<u>Family</u>	<u>Species</u>	<u>Common Name</u>	<u>Catch</u>	<u>Abundance Class</u>
Clupeidae	<i>Dorosoma petenense</i>	threadfin shad	0.00	Rare
Cyprinidae	<i>Cyprinella venusta</i>	blacktail shiner	0.58	Common
Cyprinidae	<i>Ericymba buccata</i>	silverjaw minnow	0.42	Common
Cyprinidae	<i>Hybopsis winchelli</i>	clear chub	3.42	Abundant
Cyprinidae	<i>Luxilus chrysocephalus</i>	striped shiner	4.00	Abundant
Cyprinidae	<i>Lythrurus roseipinnis</i>	cherryfin shiner	2.67	Abundant
Cyprinidae	<i>Nocomis leptosphalus</i>	bluehead chub	1.42	Common
Cyprinidae	<i>Notemigonus crysoleucas</i>	golden shiner	3.00	Abundant
Cyprinidae	<i>Notropis baileyi</i>	rough shiner	0.83	Common
Cyprinidae	<i>Notropis longirostris</i>	longnose shiner	1.67	Common
Cyprinidae	<i>Notropis texanus</i>	weed shiner	0.92	Common
Cyprinidae	<i>Notropis volucellus</i>	mimic shiner	0.00	Rare
Cyprinidae	<i>Opsopoedus emiliae</i>	pugnose minnow	1.83	Common
Cyprinidae	<i>Pimephales vigilax</i>	bullhead minnow	0.67	Common
Cyprinidae	<i>Semotilus atromaculatus</i>	creek chub	8.33	Abundant
Catostomidae	<i>Erimyzon oblongus</i>	creek chubsucker	2.25	Abundant
Catostomidae	<i>Erimyzon tenuis</i>	sharpfin chubsucker	0.00	Rare
Catostomidae	<i>Minytrema melanops</i>	spotted sucker	0.08	Common
Ictaluridae	<i>Ameiurus melas</i>	black bullhead	0.33	Common
Ictaluridae	<i>Ameiurus natalis</i>	yellow bullhead	0.58	Common
Ictaluridae	<i>Noturus funebris</i>	black madtom	0.33	Common
Ictaluridae	<i>Noturus gyrinus</i>	tadpole madtom	0.00	Rare
Ictaluridae	<i>Noturus leptacanthus</i>	speckled madtom	0.00	Rare
Ictaluridae	<i>Noturus nocturnus</i>	freckled madtom	0.17	Common
Aphredoderidae	<i>Aphredoderus sayanus</i>	pirate perch	0.42	Common
Atherinidae	<i>Labidesthes sicculus</i>	brook silverside	0.00	Rare
		blackspotted		
Fundulidae	<i>Fundulus olivaceus</i>	topminnow	4.17	Abundant
Poeciliidae	<i>Gambusia affinis</i>	mosquitofish	15.92	Abundant
Centrarchidae	<i>Ambloplites ariommus</i>	shadow bass	0.00	Rare
Centrarchidae	<i>Elassoma zonatum</i>	banded pygmy sunfish	1.00	Common
Centrarchidae	<i>Lepomis cyanellus</i>	green sunfish	6.42	Abundant
Centrarchidae	<i>Lepomis gulosus</i>	warmouth	3.58	Abundant
Centrarchidae	<i>Lepomis macrochirus</i>	bluegill	6.33	Abundant
Centrarchidae	<i>Lepomis marginatus</i>	dollar sunfish	0.75	Common
Centrarchidae	<i>Lepomis megalotis</i>	longear sunfish	5.67	Abundant
Centrarchidae	<i>Lepomis miniatus</i>	redspotted sunfish	1.33	Common
Centrarchidae	<i>Micropterus punctulatus</i>	spotted bass	0.25	Common
Centrarchidae	<i>Micropterus salmoides</i>	largemouth bass	0.50	Common
Centrarchidae	<i>Pomoxis annularis</i>	white crappie	0.00	Rare
Centrarchidae	<i>Pomoxis nigromaculatus</i>	black crappie	0.00	Rare

**Table 3.3.** continued

<u>Family</u>	<u>Species</u>	<u>Common Name</u>	<u>Catch</u>	<u>Abundant Class</u>
Percidae	<i>Ammocryta vivax</i>	scaly sand darter	0.00	Rare
Percidae	<i>Etheostoma chlorosomum</i>	bluntnose darter	1.92	Common
Percidae	<i>Etheostoma gracile</i>	slough darter	0.50	Common
Percidae	<i>Etheostoma histrio</i>	harlequin darter	0.00	Rare
Percidae	<i>Etheostoma lynceum</i>	brighteye darter	0.00	Rare
Percidae	<i>Etheostoma parvipinne</i>	goldstripe darter	4.25	Abundant
Percidae	<i>Etheostoma stigmaeum</i>	speckled darter	0.17	Common
Percidae	<i>Etheostoma swaini</i>	gulf darter	1.33	Common
Percidae	<i>Percina nigrofasciata</i>	blackbanded darter	0.00	Rare
Percidae	<i>Percina sciera</i>	dusky darter	0.00	Rare

Habitat-use weightings (Appendix A) were assigned for spawning, juvenile, and adult life stages of each species based on published information (Becker 1983, Pflieger 1975, Robinson and Buchanan 1988, and Ross 2001). These weightings are actually use probabilities, such that a weighting of 0.0 was assigned if a habitat is not used and 1.0 is assigned if a habitat is needed or is the preferred habitat. When no information about habitat use by a life stage was available, a weighting of 0.5 (i.e., equal probability that the habitat was used or not used) was assigned. Weightings between 0.5 and 0.9 were assigned when the references indicated or suggested that a habitat may be used but would not be the principal habitat; the magnitude of the score indicates the use probability or importance, e.g., a use weighting of 0.8 indicates the habitat is not the primary or preferred habitat but is more important to a life stage than a habitat with a weighting of 0.6.

Unfortunately, complete and substantial information about natural history of all fishes does not exist. Thus, the quality of the information is variable. Because a BBN is a probabilistic model, it is possible to factor in the quality of the input data. To this end, weightings were assigned ranging between 0.9, when habitat use information was substantial and definitive, and 0.5 when habitat use and importance was unstated or the references differed in habitat requirements (Appendix B). Intermediate probabilities between 0.5 and 0.9 were used when

appropriate.

Abundance probabilities are estimates that a species will be abundant, common, rare, or absent (Appendix C). Assignment of abundance probabilities recognizes that not all species will be abundant even when necessary habitats for each life state are available and that some species may remain common or rare when important habitats are removed.

The assignment of abundance probabilities for this system was based on actual estimates of abundance from the 2000-2002 Forest Service assessment of the Leaf River and tributaries (Table 3.3). Samples were collected by seining and electrofishing. Electrofishing effort was standardized and used to quantify abundance, whereas seine samples were collected with the purpose of adding to estimates of species richness (M.W. Warren, personal communication). Electrofishing catch per effort data were considered more comparable estimates of abundance among sampling sites. Of the thirteen sites sampled, one was on the mainstem Leaf River and twelve were in lower-order tributaries (Figure 3.4). The tributaries are characterized by high intermittency (M.W. Warren, personal communication), thus it was important to determine whether data from the less intermittent mainstem Leaf River station should be included with data from the Leaf River tributaries to estimate abundance. The similarity of relative abundance of fishes in the mainstem Leaf River was compared to the mean relative abundance of fishes in the Leaf River tributaries by Spearman rank correlation ( $r_s = 0.21$ ,  $n = 56$ ,  $p = 0.13$ ). The low correlation was interpreted to indicate sufficient difference between the relative abundance of fishes in the mainstem and tributaries to exclude the mainstem Leaf River sample from estimation of fish relative abundance.

Fishes collected on the main stem of the Leaf but not in its tributaries (i.e., mean electrofishing catch per site = 0) were classed as rare in the Leaf River tributaries. For example, the mimic shiner was caught in the mainstem Leaf River but not in the tributaries; therefore, the species was classified as rare. Species were classified as common if mean electrofishing catch per site was >0.0-1.99 and abundant if mean electrofishing catch per site was greater

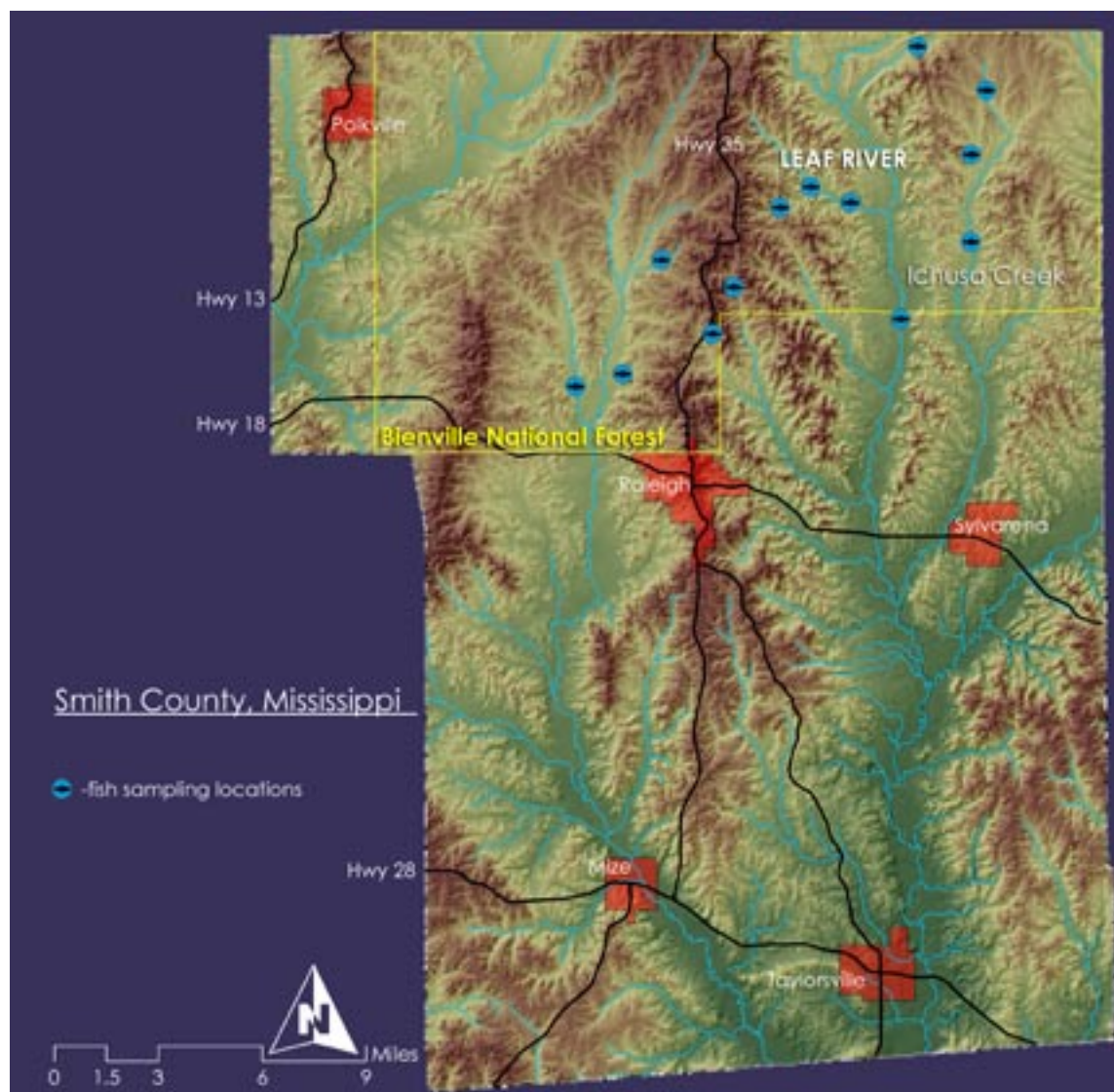


Figure 3.4. Leaf River sample locations

than  $\geq 2.00$  (Appendix D).

Population abundance probabilities were estimated for “best-case” (i.e. conditions conducive to high success of all life stages) and “worst-case” habitat conditions. Probabilities for the best conditions reflect current population status, yet recognize that present abundance may increase by improvement or addition of needed habitats; in other words, the current habitat conditions are not inferred to be “ideal” habitat conditions. Unless a unique habitat requirement (e.g., highly specific spawning requirements) dictated special consideration, all fish classified as rare were assigned the same probabilities for best habitat conditions; a different, but consistent, set of abundance probabilities were assigned for fish classed as common, and a different set of probabilities were developed for fish classed as abundant (Appendix C). By similar reasoning, the probability matrices were constructed for different population abundance classes for worst habitat conditions.

Several examples are offered to demonstrate how abundance probabilities were assigned. The mimic shiner was present in the main stem Leaf River but not in any of the 12 tributary streams sampled. Thus, its abundance classification is “rare”. For “best-case” conditions and as defined in Appendix E, a 0.5 probability was assigned that the mimic shiner would be rare (its present abundance classification), 0.4 probability that it would be common, and 0.1 probability that it would be abundant.

Assignments of these probabilities, while somewhat arbitrary, are based on the assumption that present habitat conditions may not be the best-case conditions. The silverjaw minnow was classified as common based on Forest Service catch rates (Appendix D). Under best-case conditions, the species would not be less abundant but may be more abundant. Thus, a 0.7 probability was assigned that the species might be common and 0.3 probability that the abundance could increase. Species that were classified as abundant, like the striped shiner or golden shiner, were assigned 0.9 probability that they would remain abundant and a 0.1 probability that abundance would decline to common for best-case conditions.

The fish used for the previous examples are presently abundant even though the habitat conditions may not be the best for these species, it cannot be assumed that the species will remain abundant under best-case habitat conditions. For example, as habitat conditions improve, a competing species may increase in abundance and negatively affect abundance of the species of concern. Probabilities for the worst conditions also reflect current status yet recognize the ability to decline in abundance due to habitat degradation or loss. The silverjaw minnow is common based on current abundance; under “worst-case” habitat conditions, there is a high likelihood silverjaw minnow abundance would decline; therefore, the probability of remaining common is only 0.1. The species has rather general flowing water requirements (Appendix A), and riffles and runs are prevalent habitats in the Leaf River tributaries. Since an impoundment, regardless of where sited, will not eliminate riffles and runs, they will remain in a worst-case condition. A 0.7 probability that the species will decline in abundance to rare was assigned and only a 0.2 probability that it will be extirpated. On the other hand, the rough shiner, presently common, has very specific spawning requirements—the rough shiner spawns over bluehead chub nests which are restricted to gravel riffles. Gravel is relatively scarce in the upper Leaf system. Therefore a greater probability (0.3) was assigned, compared to the 0.2 of the silverjaw minnow, that the rough shiner will be extirpated under worst-case habitat condition.

The BBN for this research project is habitat driven. Habitats available to fishes in the upper Leaf River tributaries are backwaters, floodplain lakes, riffles, runs, and pools. An example of the BBN template used for this project is shown in Figure 3.5. Within the BBN, these habitats are referred to as parent states which in turn directly relate to three life stages, known as child states. This parent/child relationship is represented by arrows, connecting life stages to habitats used during each. Population Status is a child state directly related to its three parent Life Stage states. Each state consists of variables. These variables are unique in that they represent the probabilities that are passed down to each related child state. Because



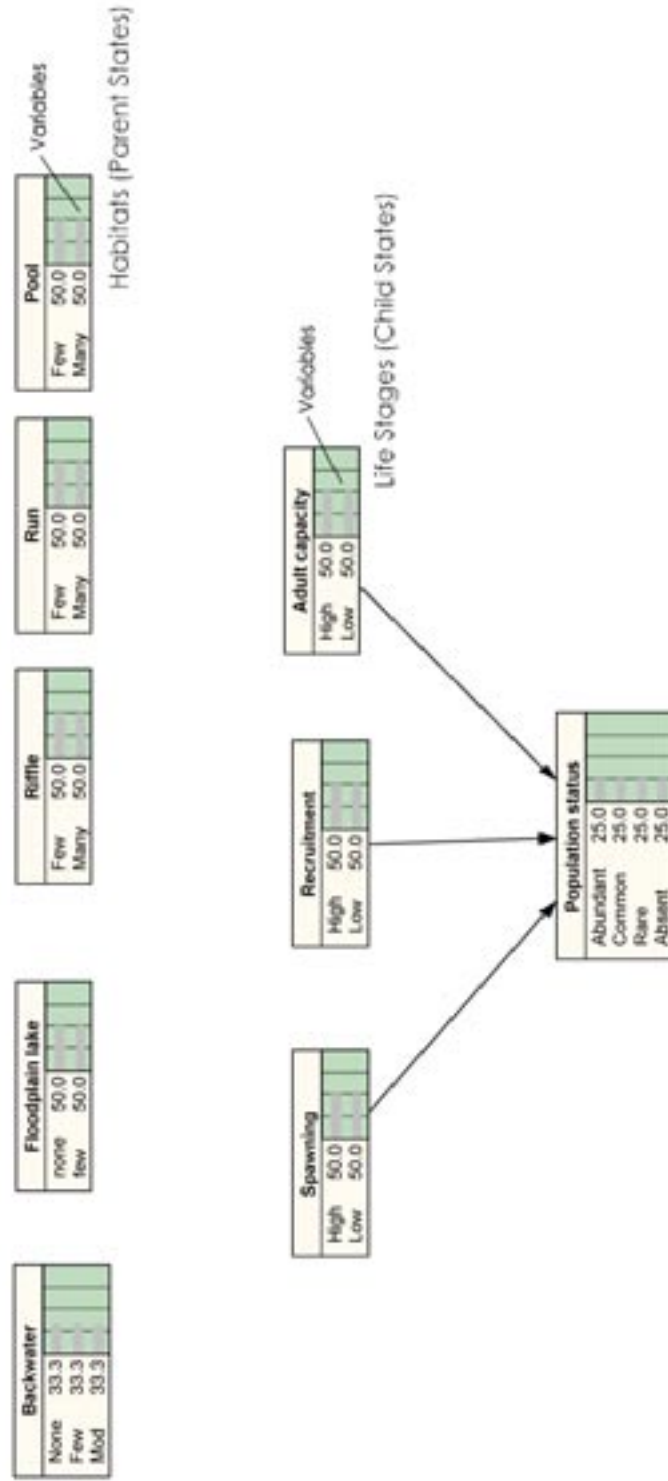


Figure 3.5. Generic BBN template

of these percentages and the given relationship between Life Stages and Population Status, the BBN is able to calculate the four Population Status variables: abundant, common, rare, and absent. These values represent the abundance probability for each fish given the provided habitat configuration.

In the case of the habitat/life stage relationships, only those habitats used per life stage were connected and because all life stages are integral in depicting the population status of a fish, all life stages relate and therefore connect directly to population status. It is through these parent child relationships that the BBN can calculate the population abundance for each fish given any habitat combination.

With the completion of data input, the BBN model was run for each fish. This is accomplished by inputting values for each habitat variable. Two BBN models (pre- and post- impoundment) were built for each species so that probabilities of occurrence could be calculated and analyzed for fishes before and after the development of the impoundment. The pre-impoundment habitat variables were populated using knowledge garnered through a site visit to the sampling locations of the forest service fish survey and aerial photography, while the post-impoundment numbers were populated with habitat percentages calculated based on an aquatic habitat inventory of the affected area of Ichusa Creek conducted in May 2005 and with the understanding that with the flooding of the impoundment, all stream habitats within the impoundment will be lost, although all habitats up-stream of the impoundment will remain accessible. Due to no migration beyond the control structure, the study area is now confined between the control structure and the headwaters.

The pre-impoundment BBN models (Figure 3.6) were constructed for each fish using current habitat percentages. These percentages are the variables associated with the different habitat states and were garnered through site visits. Through the study of aerial imagery and a site visit it was determined that the Leaf River system within Smith County and the Bienville National Forest currently has a high number of pools and runs, a moderate number of riffles,



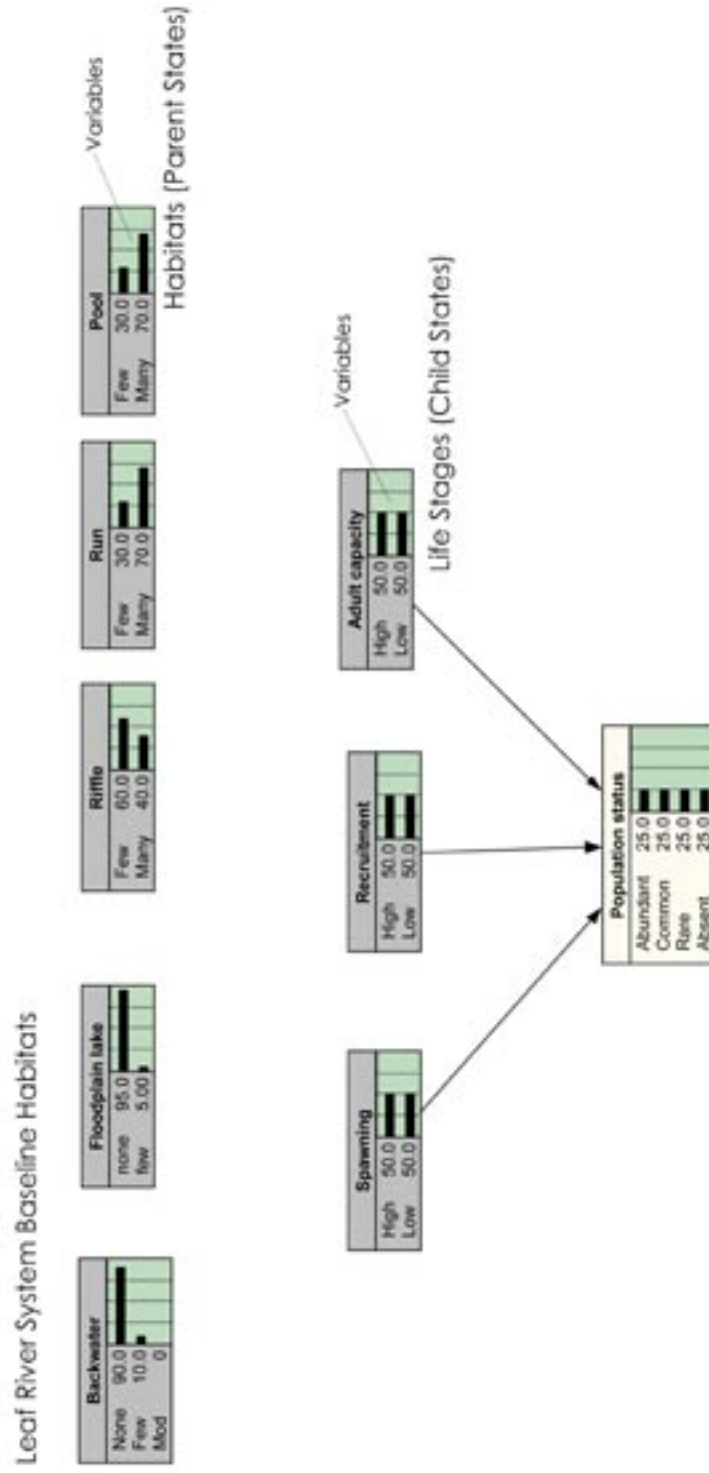


Figure 3.6. Leaf River system baseline BBN model.

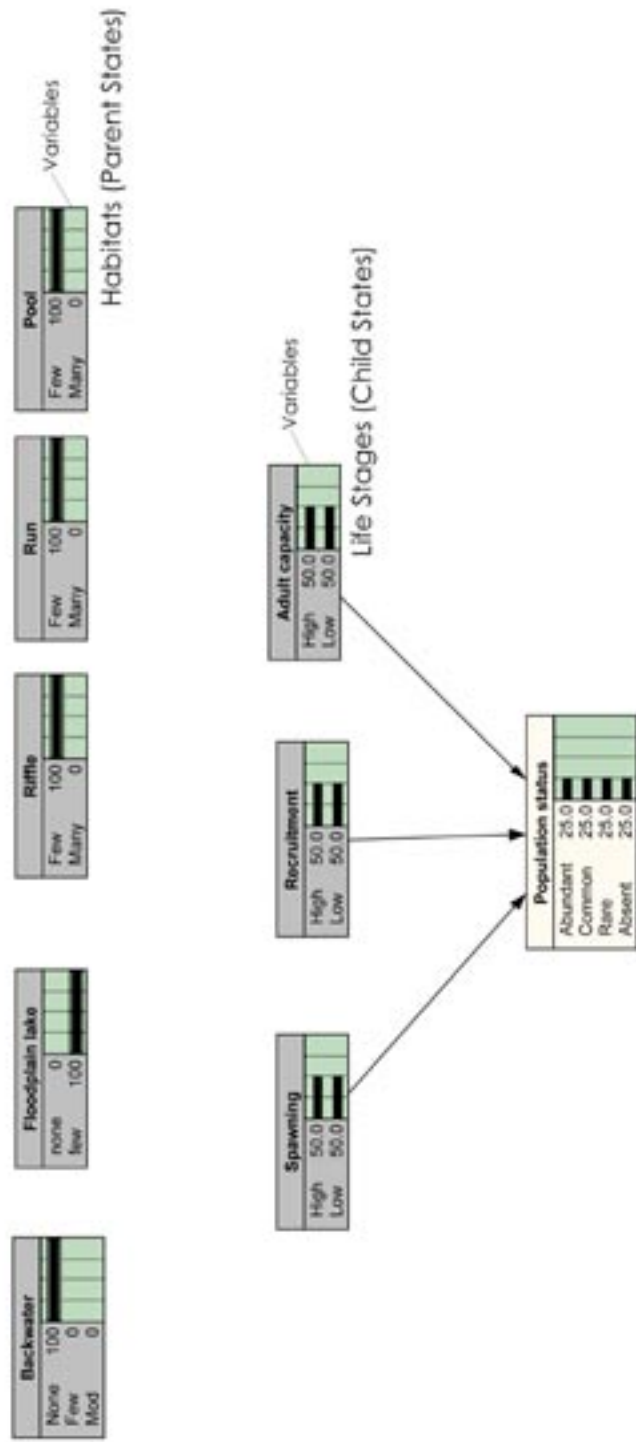
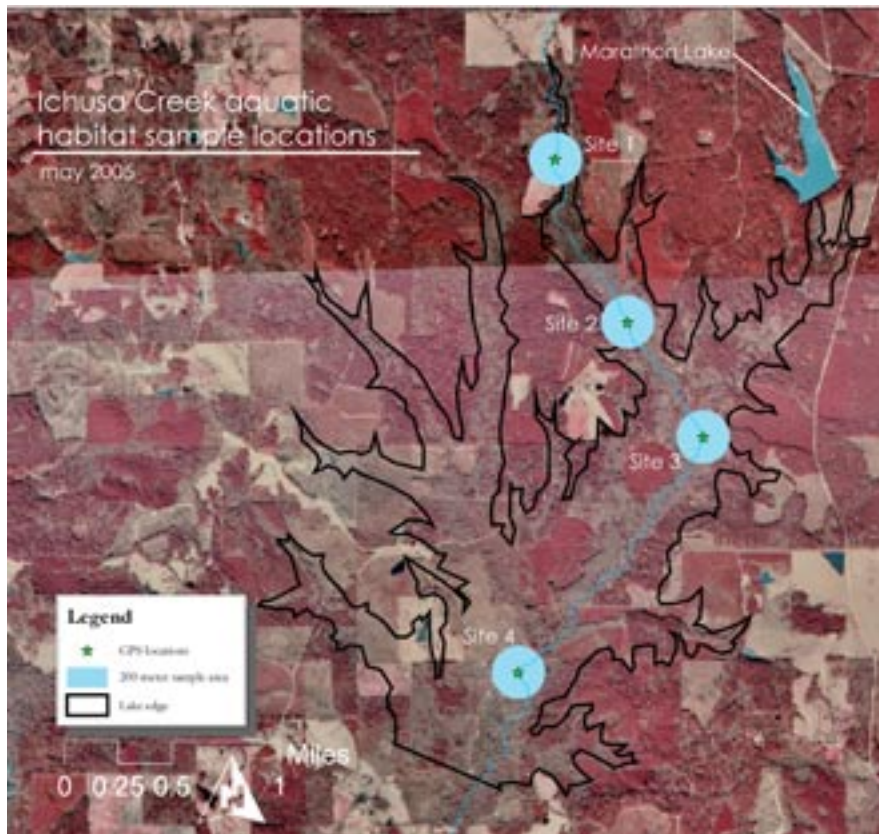


Figure 3.7. Ichusa Creek impoundment BBN model

very few backwaters, and is almost void of floodplain lakes. With this understanding of current habitats, Figure 3.6 shows the base BBN model with the baseline habitat numbers representing current aquatic habitats within the Smith County Bienville National Forest Leaf River system. With these inputs of habitat percentages, the model updates all related spawning and population status states using the current habitat variable composition.

In order for the BBN to become a model specific only to the impoundment site, aquatic habitats need to be quantified so that the post-impoundment BBN model can be constructed (Figure 3.7). The part of Ichusa Creek that will be affected by the impoundment was inventoried for five aquatic habitat types; these include backwater, floodplain lakes, riffle, run, and pool as previously described in this chapter. In May of 2005, four locations (Figure 3.8) within the impoundment site of Ichusa Creek were inventoried and the locations were recorded using a Garmin GPS. From each GPS location, 200 meters of Ichusa Creek were



**Figure 3.8.** Ichusa Creek 200 meter sample locations.

inventoried and walked below and above the GPS point for a total of 400 meters inventoried per location (Table 3.4). The presence/absence of the habitats were recorded and totaled for each section inventoried. Of the 6,035 meters of Ichusa Creek within the impoundment site, 1,600 meters were sampled.

**Table 3.4.** Sample locations and habitats inventoried. Backwater (BW), Floodplain lake (Fpl), Riffle, Run and Pool habitats inventoried May 2005 within the hypothetical Ichusa Creek impoundment site.

Sample site	Meters inventoried	Water in channel	Flowing water	Bw	Fpl	Riffle	Run	Pool
Site 1	400	no	none	0	0	0	0	0
Site 2	400	no	none	0	0	0	0	0
Site 3	400	yes	minimal	0	0	0	17	6
Site 4	400	yes	minimal	0	0	0	24	11

With aquatic habitat occurrence numbers for the Ichusa Creek impoundment site, it is possible to calculate inputs for each habitat variable. Once the occurrence of habitats within the impoundment site was known a BBN model was constructed for each fish with habitat variables which reflect the habitats available within the impoundment so that a comparison could be run between the test impoundment site and the current Leaf River model population abundance numbers.

For the sake of this study, the 50 species of fish have been partitioned into three categories based on their habitat needs (1) generalists - fishes that have the ability to utilize riverine and backwater environments (2) river-dependent – fishes that utilize riverine, flowing habitats (3) backwater-dependent – fishes that utilize backwaters or other sluggish or slack water environments. This was done in order to test the model by determining the effects of the impoundment on fish of different habitat needs and pre-impoundment abundance.

### 3.5 – Conclusion

With both BBN and GAP, considerable data preparation was required before any

analysis could be done. Fish survey data was filtered, a test site and aquatic habitats delineated, and the BBN constructed, while GAP data was subset and readied for analysis using GIS and remote sensing tools. The river system habitats were spatially delineated, an impoundment site was digitized so that GAP data and effected aquatic habitats could be quantified, and the BBN was populated with habitat variables indicative of the effected area.

## **CHAPTER IV**

### **RESULTS AND DISCUSSION**

#### **4.1 – Introduction**

This chapter demonstrates the output of the SDSS to assess the impacts of a hypothetical impoundment. To test the SDSS an impoundment was located on Ichusa Creek. Results and discussions for terrestrial systems include analysis of landcover, species, and species richness. For aquatic environments a habitat analysis is available along with comparisons of abundance probabilities between the Leaf River and Ichusa Creek impoundment BBN models of selected fish.

#### **4.2 – Terrestrial**

##### **4.2.1 – Landcover**

Smith County totals 408,386.8 acres and has 23 landcover types (Table and Figure 4.1). Of these landcovers, the three major types are medium density pine with 108,350 acres, low herbaceous vegetation with 55,082.9 acres, and grassy/pasture/range with 54,701.5 acres (Table 4.1).

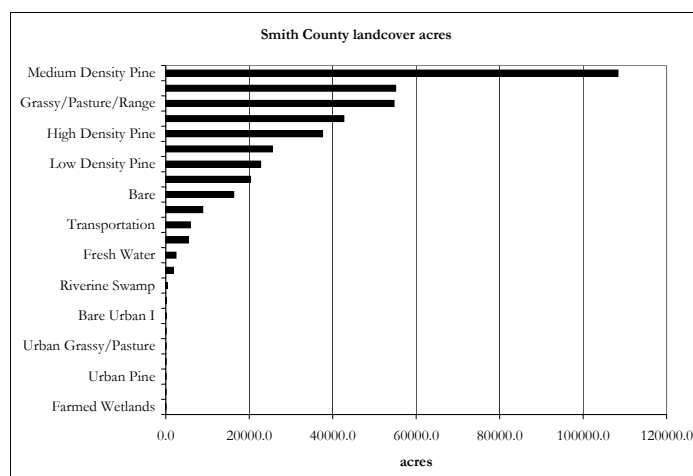
The Bienville National Forest in Smith County contains 133,509 acres comprised of 17 landcover types (Table and Figure 4.2). The three major types being medium density pine with 40,383.8 acres, low herbaceous vegetation with 15,245.3 acres, and high density pine with 14,543.6 acres.

The hypothetical impoundment site is 1,798.7 acres comprised of 11 landcover types (Table and Figure 4.3). The largest two types are medium density pine with 703.4

acres and medium density hardwoods with 302.9 acres.

**Table 4.1.** Smith County Landcovers - acreage and percentages

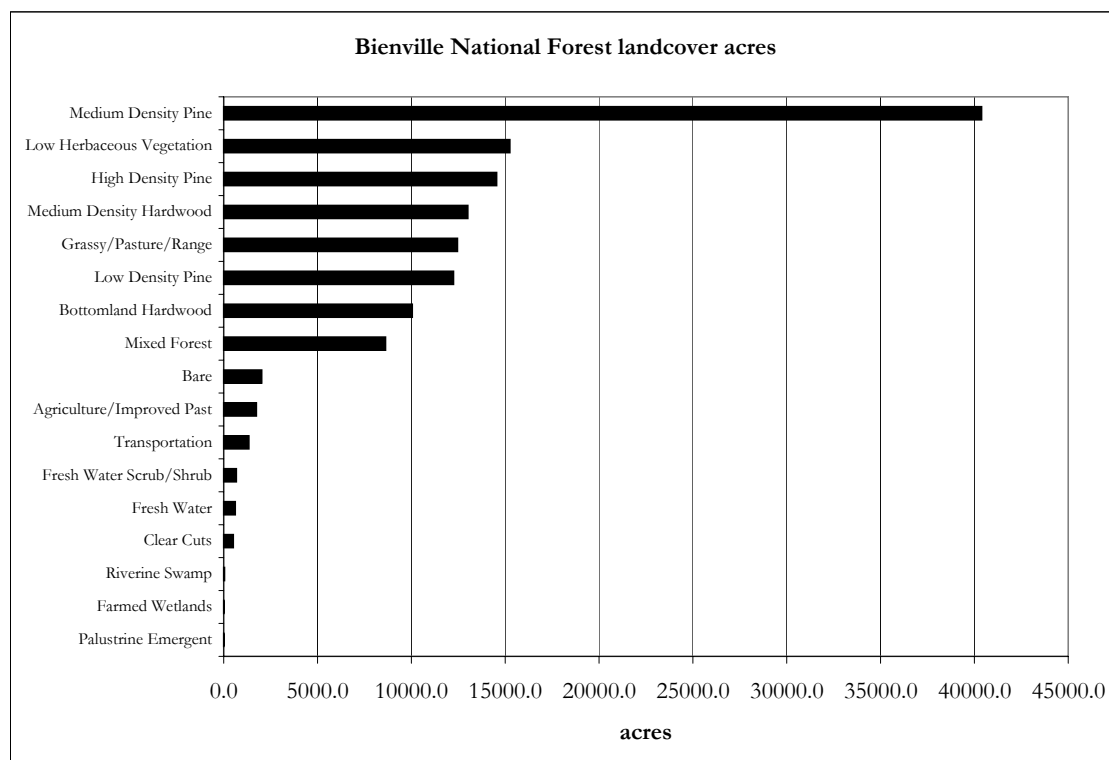
Landcover	Acres	% of total
Farmed Wetlands	8.5	0.00%
Urban Hardwood	20.5	0.01%
Urban Pine	34.7	0.01%
Palustrine Emergent	42.3	0.01%
Urban Grassy/Pasture	43.6	0.01%
Bare Urban II	48.9	0.01%
Bare Urban I	85.8	0.02%
High Density Urban	105.6	0.03%
Riverine Swamp	364.7	0.09%
Clear Cuts	1844.3	0.45%
Fresh Water	2452.7	0.60%
Fresh Water Scrub/Shrub	5391.0	1.32%
Transportation	5852.9	1.43%
Agriculture/Improved Pasture	8842.4	2.17%
Bare	16286.5	3.99%
Bottomland Hardwood	20290.6	4.97%
Low Density Pine	22729.1	5.57%
Mixed Forest	25579.3	6.26%
High Density Pine	37567.7	9.20%
Medium Density Hardwood	42661.1	10.45%
Grassy/Pasture/Range	54701.5	13.39%
Low Herbaceous Vegetation	55082.9	13.49%
Medium Density Pine	108350.2	26.53%
Total	408386.8	



**Figure 4.1.** Smith County landcovers and acreages

**Table 4.2.** Bienville National Forest, Smith County Landcovers - acreage and percentages

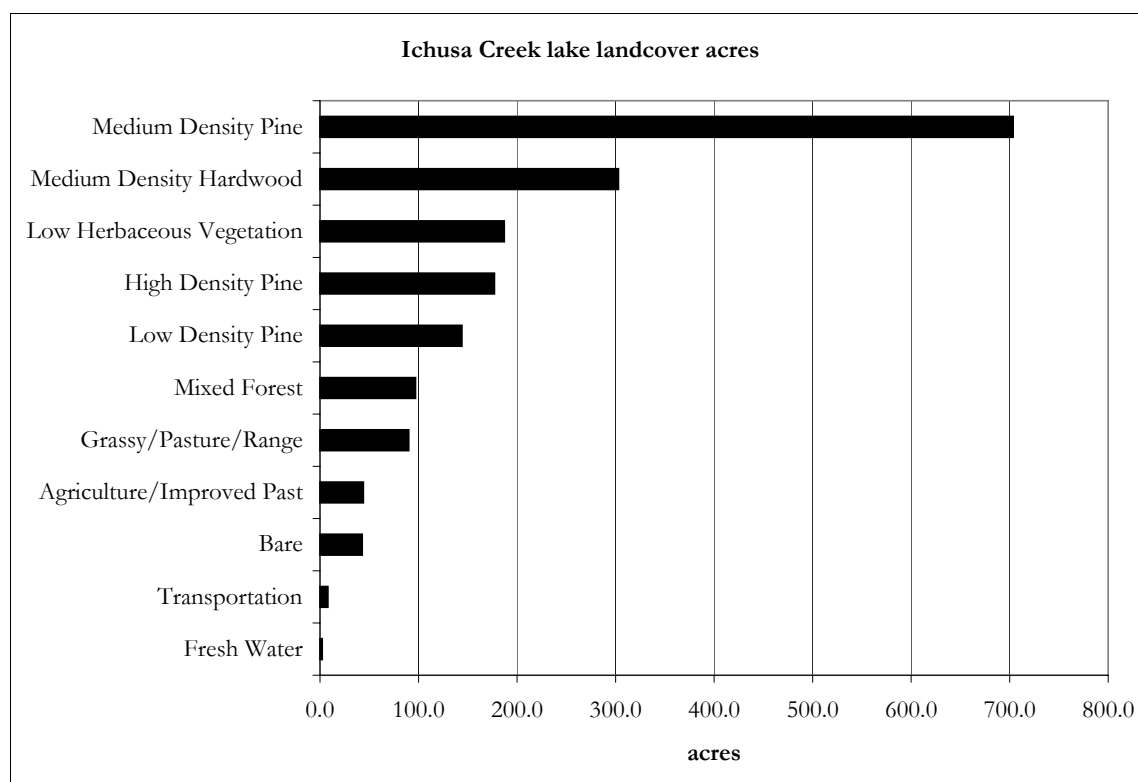
Landcover	Acres	% of total
Palustrine Emergent	6.5	0.00%
Farmed Wetlands	8.5	0.01%
Riverine Swamp	42.3	0.03%
Clear Cuts	510.6	0.38%
Fresh Water	612.7	0.46%
Fresh Water Scrub/Shrub	675.4	0.51%
Transportation	1340.3	1.00%
Agriculture/Improved Pasture	1740.0	1.30%
Bare	2022.2	1.51%
Mixed Forest	8621.4	6.46%
Bottomland Hardwood	10048.7	7.53%
Low Density Pine	12244.4	9.17%
Grassy/Pasture/Range	12454.7	9.33%
Medium Density Hardwood	13008.7	9.74%
High Density Pine	14543.6	10.89%
Low Herbaceous Vegetation	15245.3	11.42%
Medium Density Pine	40383.8	30.25%
Total	133508.9	

**Figure 4.2.** Bienville National Forest landcovers and acreages



**Table 4.3.** Ichusa Creek impoundment site landcovers - acreage and percentages

Landcover	Acres	% of total
Fresh Water	2.2	0.12%
Transportation	8.0	0.45%
Bare	42.9	2.39%
Agriculture/Improved Past	44.0	2.45%
Grassy/Pasture/Range	90.1	5.01%
Mixed Forest	97.0	5.39%
Low Density Pine	144.1	8.01%
High Density Pine	177.0	9.84%
Low Herbaceous Vegetation	187.0	10.40%
Medium Density Hardwood	302.9	16.84%
Medium Density Pine	703.4	39.11%
Total	1798.7	

**Figure 4.3.** Ichusa Creek impoundment site landcovers and acreages

With quantitative landcover information, it is possible to assess the potential loss of landcover due to the development of the hypothetical Ichusa Creek impoundment.

The impoundment site has no unique landcovers. From a percentage standpoint, the impoundment site is comprised of less than 2% of the Bienville National Forest land area and the landcovers closely reflect this with no impoundment site landcover being more than 2.5% of their respective Bienville National Forest landcover (Table 4.4).

**Table 4.4.** Bienville National Forest and Ichusa Creek impoundment site landcovers and percentages.

Landcovers	Bienville National Forest (acres)	Ichusa Creek Site (acres)	Ichusa creek site/ Beinville NF
Palustrine Emergent	6.5	0	0.00%
Farmed Wetlands	8.5	0	0.00%
Riverine Swamp	42.3	0	0.00%
Clear Cuts	510.6	0	0.00%
Fresh Water Scrub/Shrub	675.4	0	0.00%
Bottomland Hardwood	10048.7	0	0.00%
Fresh Water	612.7	2.2	0.36%
Transportation	1340.3	8	0.60%
Grassy/Pasture/Range	12454.7	90.1	0.72%
Mixed Forest	8621.4	97	1.13%
Low Density Pine	12244.4	144.1	1.18%
High Density Pine	14543.6	177	1.22%
Low Herbaceous Vegetation	15245.3	187	1.23%
Medium Density Pine	40383.8	703.4	1.74%
Bare	2022.2	42.9	2.12%
Medium Density Hardwood	13008.7	302.9	2.33%
Agriculture/Improved Past	1740.0	44	2.53%
<b>Landcover sums (acres) and mean percentage</b>	<b>133508.9</b>	<b>1798.6</b>	<b>1.35%</b>

#### 4.2.2 – Species

Although species occurrence maps are suggestions of possible occurrence and do not offer definitive occurrence, they do give spatial definition to a species' possible range. A

species/landcover matrix provides the needed information to estimate possible species per study area (Smith County, Bienville National Forest in Smith County, or the Ichusa Creek impoundment site). Such data can be useful in locating threatened or endangered species.

Four species that GAP listed as having a possible occurrence in Smith County are federally threatened or endangered (Threatened and Endangered Species System, 2004) (Table 4.5).

**Table 4.5.** Threatened and endangered species. Threatened and endangered species, landcovers used, and current status found in the three different study areas (Smith County, Bienville National Forest in Smith County, and the Ichusa Impoundment site)

Study area threatened or endangered species

Common name	Landcovers	Status	Locations found
American Alligator	Freshwater Farmed Wetland Palustrine Emergent Bottomland Hardwood Freshwater Scrub/Shrub	Threatened	Smith County, Bienville National Forest Ichusa Impoundment site
Bald Eagle	Bottomland Hardwood Low Density Pine	Threatened	Smith County, Bienville National Forest Ichusa Impoundment site
Ringed Map Turtle	Freshwater Bottomland Hardwood	Threatened	Smith County, Bienville National Forest Ichusa Impoundment site
Red-Cockaded Woodpecker	Low Density Pine	Endangered	Smith County, Bienville National Forest Ichusa Impoundment site

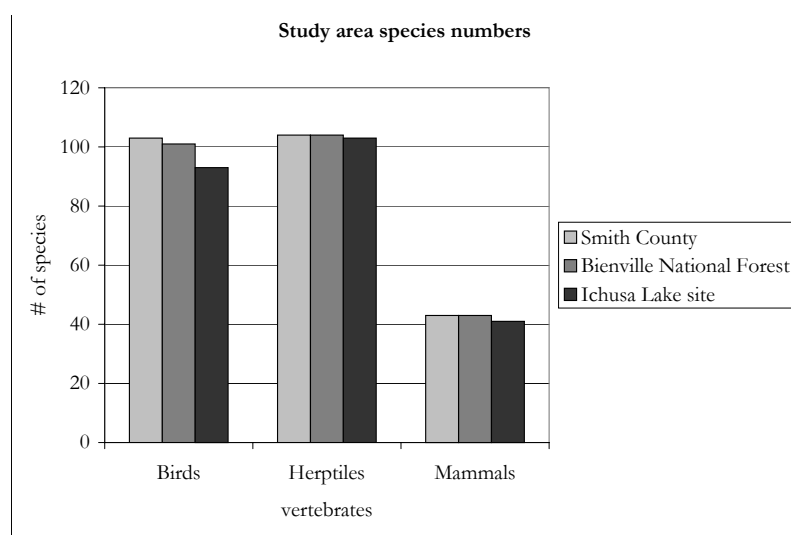
No information was available regarding the definitive occurrence of the american alligator, bald eagle, or ringed map turtle within the study area, however it is known that the Bienville National Forest has one of the largest populations of red-cockaded woodpeckers in the state (Vilella, personal communication). The red-cockaded woodpecker (RCW) prefers

low density pine and the Ichusa Creek impoundment site would eliminate 144 acres of this habitat type. Although this is only 1.18% of the overall low density pine stand in the Bienville National Forest, efforts should be made to protect this endangered species from further habitat loss and degradation. A colony inventory for the RCW was not available and out of the scope of this project. It is not known if the three other threatened species actually occur within the Ichusa Creek impoundment site. If any of these species are found to occur; the colony, last known location, nest site, etc. should be located with a GPS and incorporated into ArcGIS.

It was found that Smith County had 103 species of birds, 104 species of herpetiles and 43 species of mammals. The Bienville National Forest in Smith County had 101 species of bird, 104 species of herpetiles, and 43 species of mammals, while the Ichusa Impoundment site has 93 species of birds, 103 species of herpetiles and 41 species of mammals (Figure 4.4).

#### 4.2.3 – Species Richness

Species richness was calculated for each vertebrate category (birds, herpetiles, and mammals) for each pixel. These values represent the number of species which have been



**Figure 4.4.** Study area species numbers. Vertebrates and their numbers listed per study area

found to utilize that pixel's landcover.

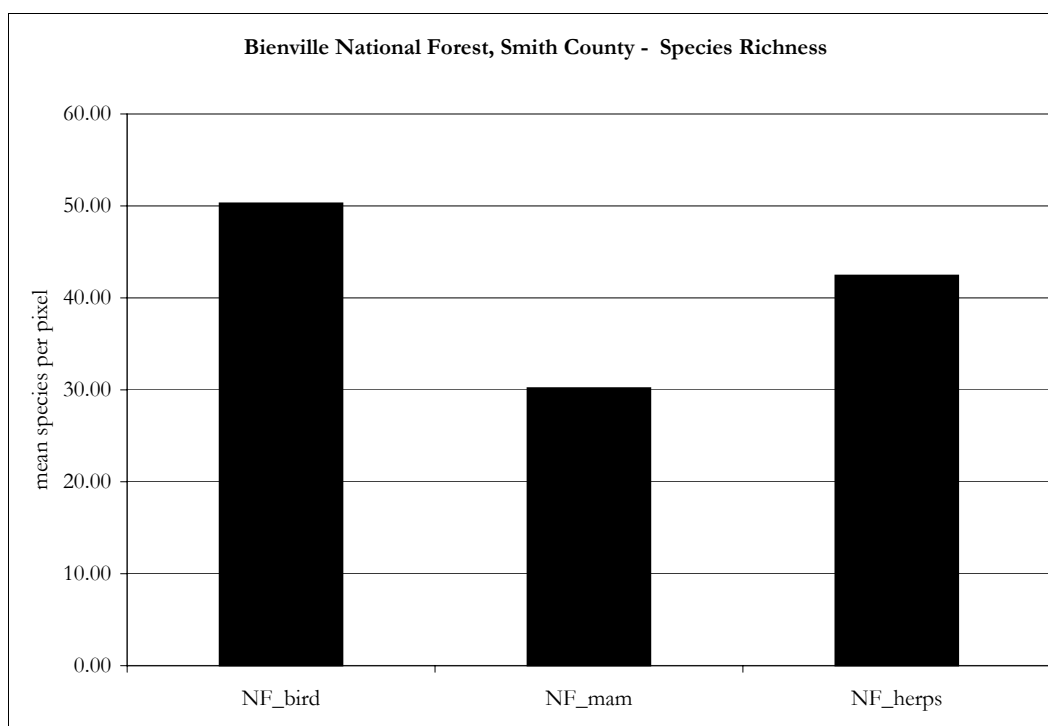
At the county scale, 30 different values of species richness were found for birds ranging from 0 to 89 species per pixel. It was found that Smith County's weighted species richness mean for birds was 38.94 species per pixel, 24.14 for mammals, and 30.65 for herpetiles (Figure 4.5).

The Bienville National Forest landcover in Smith County is 74.4% mature woody vegetation. Of Smith County's woody vegetation, 38.4% is located within the boundary of Bienville National Forest. Within the National Forest the weighted mean species richness for birds was 50.30 species per pixel, 30.19 for mammals, and 42.44 for herpetiles with an overall mean of 40.97 (Figure 4.6).

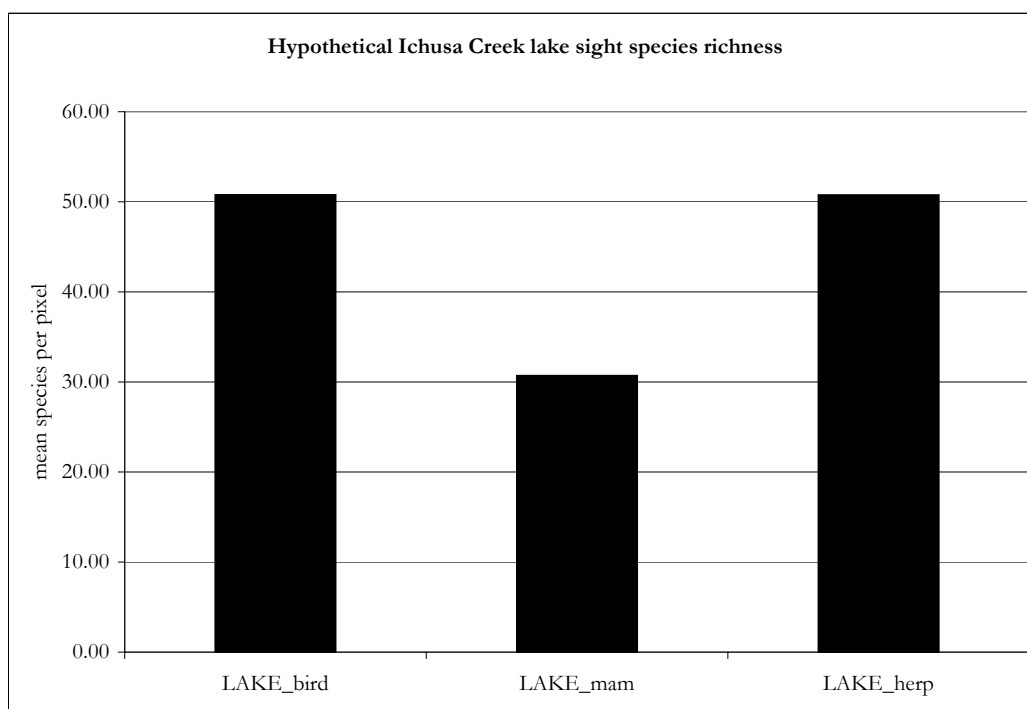
The hypothetical impoundment site shares similar species richness values comparable to those of the Bienville National Forest. It was found that the weighted mean impoundment sight species richness for birds was 50.78 species per pixel, 30.71 for mammals, and 50.77 for herpetiles with an overall mean of 44.08 (Figure 4.7).

#### **4.2.4 – Terrestrial summation**

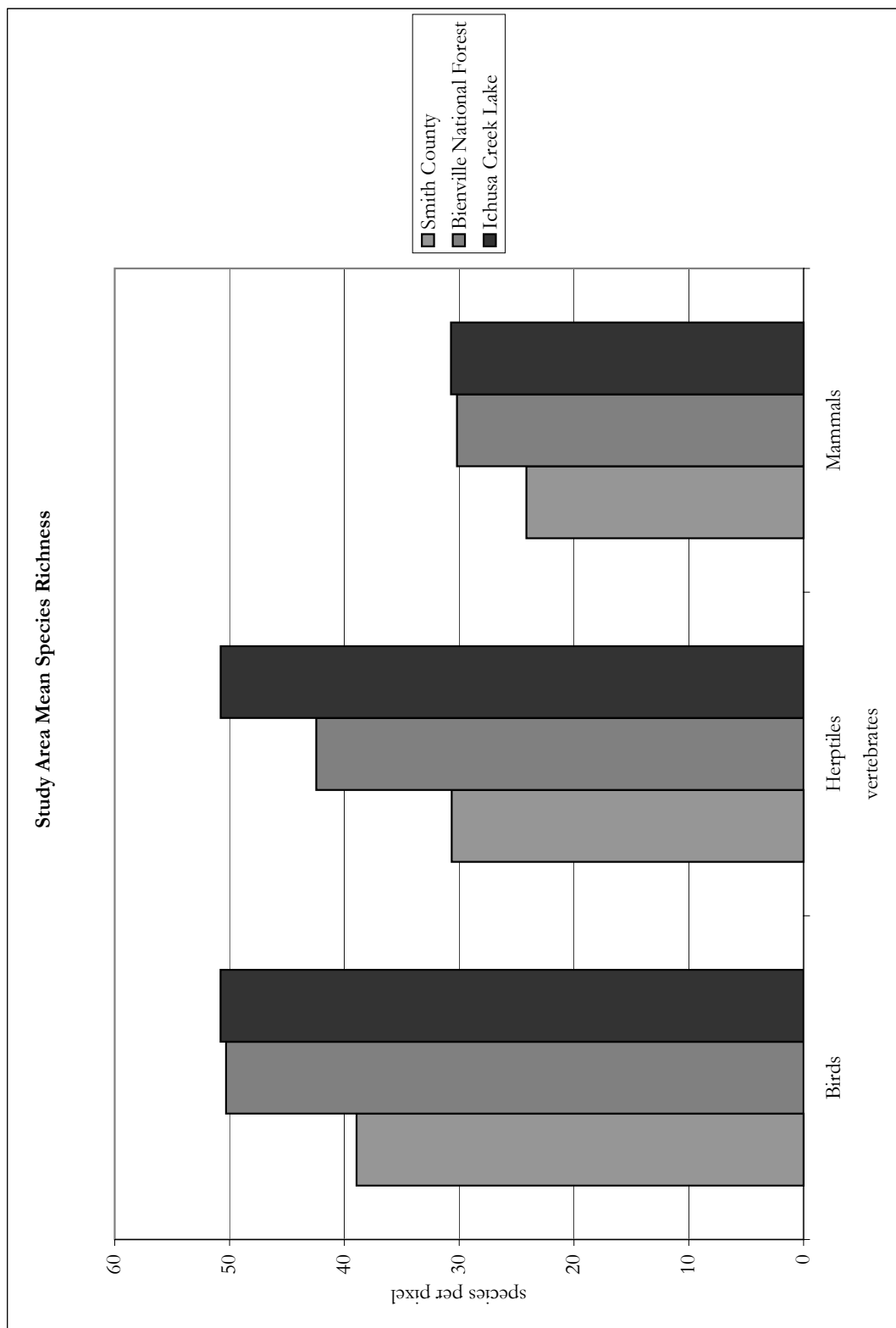
Even with its small land area (Table 4.3), the Ichusa impoundment site has similar landcovers, number of species, and species richness values (Figure 4.8) as that of both Smith County and the Bienville National Forest. The Ichusa Creek impoundment site shares the same species as Smith County and Bienville National Forest. With this comparison of landcover, species, and species richness, it was found that with the development of the impoundment on Ichusa Creek, no unique landcovers species, or areas high in richness would be lost. However as noted before, special care should be taken to avoid the removal or degradation of habitats used by threatened or endangered species.



**Figure 4.5.** Bienville National Forest, Smith County species richness. Weighted means values for birds, mammals, and herpetiles



**Figure 4.6.** Hypothetical impoundment sight species richness. Weighted means values for birds, mammals, and herpetiles



**Figure 4.7.** Study area mean species richness. Weighted means values for birds, mammals, and herptiles for Smith County, Bienville National Forest, and the Ichusa Creek lake site.

### 4.3 – Aquatic

#### 4.3.1 – Habitats

For each species there were two BBN models produced. The first having habitat numbers indicative of the Leaf River system within Smith County and the Bienville National Forest and the second having habitat numbers reflecting post-impoundment habitat conditions of the Ichusa Creek impoundment site. With these two models it is possible to compare population status probabilities for each species and see the resulting changes in overall population status, due to the development of the Ichusa Creek impoundment. The habitat variables input into the Leaf River and post-impoundment BBN models are shown in Table 4.6 and described below.

**Table 4.6.** Probabilities of habitat occurrence. The habitat variables input into each habitat state within the Leaf River and Ichusa Creek impoundment BBN models. Probabilities for available habitats for the Leaf River system based on site visits and communication with the Forest Service fish survey conductor and the Ichusa Creek impoundment site probabilities based on the aquatic survey of May 2005 and the loss or gain of habitats due to impoundment. Explanations of probabilities follow.

Habitats	occurrence	Leaf River	Ichusa Creek Impoundment
Backwaters	none	90	100
	few	10	0
	moderate	0	0
Flood plain lake	none	95	0
	few	5	100
Riffle	few	60	100
	many	40	0
Run	few	30	100
	many	70	0
Pool	few	30	100
	many	70	0



All sampling locations associated with the Forest Service fish survey were visited and through the inventory and communication with Mel Warren, who conducted the fish survey, it was determined that there are currently very few backwaters, floodplain lakes, and riffles and that the current Leaf River system is dominated with run and pool habitats. With this knowledge, it was possible to input habitat variables for the Leaf River BBN. Because of the lack of backwaters and floodplain lakes in the current system, it was input that there is a 90% chance for none, 10% chance for few and 0% chance for many backwaters and a 95% chance for none and 5% chance for few floodplain lakes in the current system. There is a lack of riffles, however some are present, therefore it was input that there is a 60% chance for few and 40% chance for many riffles. Knowing that the current system is dominated with run and pool habitats, both were input with 30% chance for few and 70% chance for many being accessible within the system.

Within the four inventory locations within the hypothetical Ichusa Creek impoundment site, of which two were dry, there are 0 riffles, 41 runs, 0 backwaters, 17 pools, and 0 floodplain lakes (Table 3.4). These numbers were sampled in May 2005. It was found during the aquatic inventory that over 50% of Ichusa Creek within the impoundment site was intermittent and at the time of the survey only had puddles of water within the channel with no flow. From site 3 southward, water was found in the channel; however it was apparent flows were at a minimum. Site 3 is located at the point in which the Marathon Lake spillway runs into Ichusa Creek, hence the increased amount of water within Ichusa Creek below site 3. Without the water input from the lake, this system would have very minimal flow and water for a large part of the year. Because of this, viable habitats and established fish populations are presently scarce and would only be aided by the impoundment of water which would increase habitat as well as increase flow for downstream systems.

With the development of the impoundment all sections of Ichusa Creek which had water during the aquatic habitat inventory will be lost due to flooding, therefore no

backwaters, riffles, runs, or pools will be accessible to fish within the impoundment, hence the 100% chance for none backwaters and 100% chance for few riffles, runs, and pools. Due to the impoundment of water above the control structure, the reservoir will produce a sluggish-water environment and essentially provide habitat similar to that of a floodplain lake, therefore the 100% probability that floodplain lake habitats will be available and the 100% chance for few floodplain lakes. The original BBN was constructed with the entire Leaf River system in mind and with the assumption that riffle, run and pool habitats would always be accessible, therefore these three habitats lack the variable option of none. The same logic applies to floodplain lake and it not having a many habitat variable similar to the other habitat states because of the assumption that many floodplain lake would never be accessible.

#### 4.3.2 – Species

Based on habitat use information (Appendix A), 15 fish were classed as general, 13 as riverine, and 22 as backwater. In order to assess the impacts of the test site on fish of different abundances and habitat needs, three species from each habitat class were randomly selected from each fish abundance category (abundant, common, or rare).

From the general habitat class the three fish are: creek chubsucker (abundant), black madtom (common), dusky darter (rare). From the riverine habitat class: clear chub (abundant), silverjaw minnow (common), and brighteye darter (rare) were chosen. From the backwater class: bluegill (abundant), blackbull head (common), and white crappie (rare) were chosen for case studies.

Table 4.6 shows the habitat probabilities input as habitat variables for both the Leaf River and post-impoundment BBN models. Both models were run and compared because with the comparison of these models it is possible to understand the impacts of the impoundment on population probabilities of fish within the impoundment site. The tables and BBN models comparing the fish from each habitat and abundance classification follow.

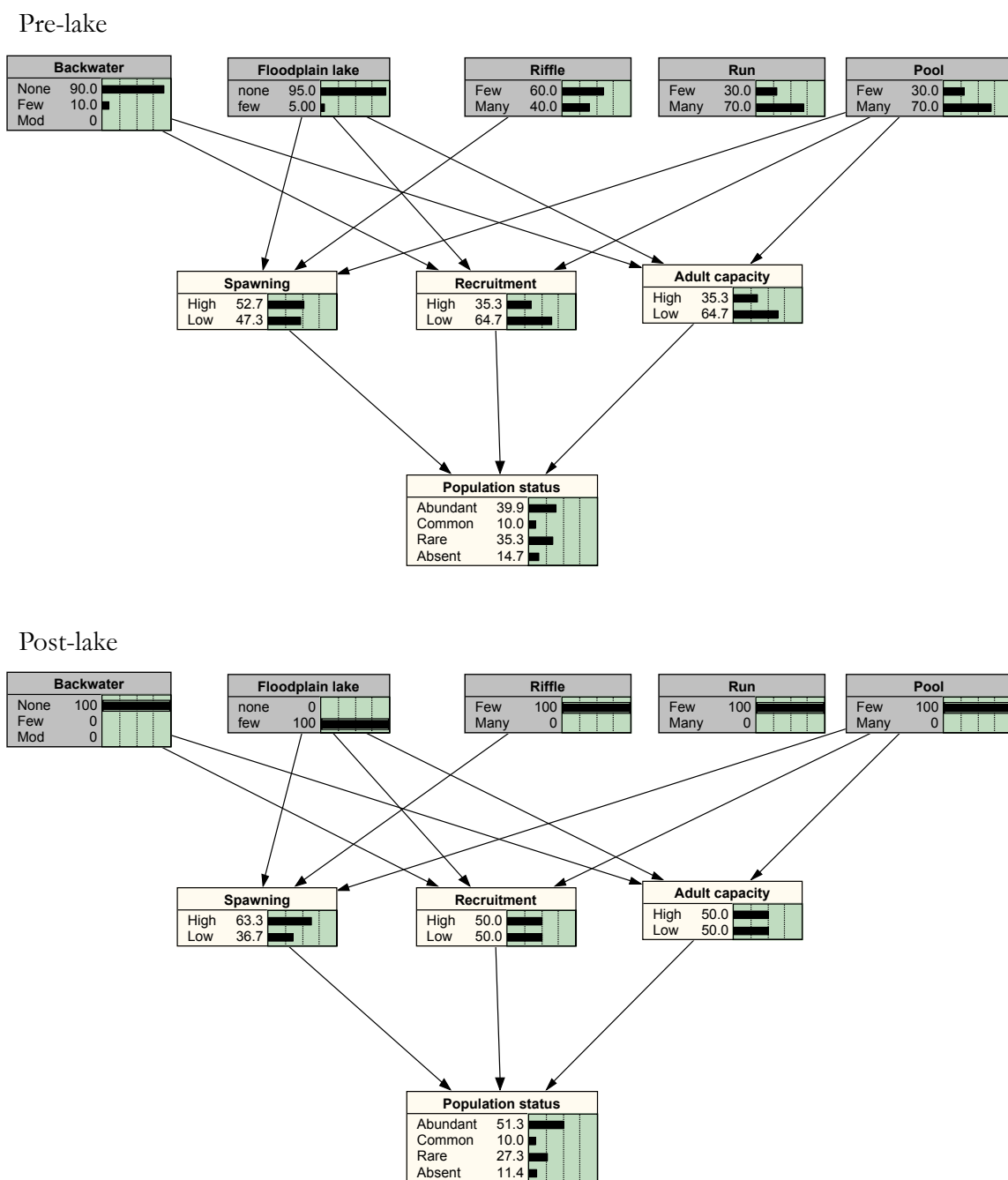
### 4.3.3 – General Fish

Of the three general fish, the abundantly classed creek chubsucker is the only fish to exhibit an improvement in population status with post-impoundment habitats. As shown in Table 4.7, the presently abundant creek chubsucker (Figure 4.8) was 11.4% more likely to be abundant and 8% less likely to be rare following impoundment. The black madtom (Figure 4.9), a common fish with the current Leaf River habitat configurations, shares somewhat different probabilities and was 5.6% less likely to be abundant and 13.1% more likely to be rare following impoundment. The rare dusky darter (Figure 4.10) also showed a decline in abundance and was 1.85% less likely to be abundant and 1.5% more likely to be rare following impoundment (Table 4.7).

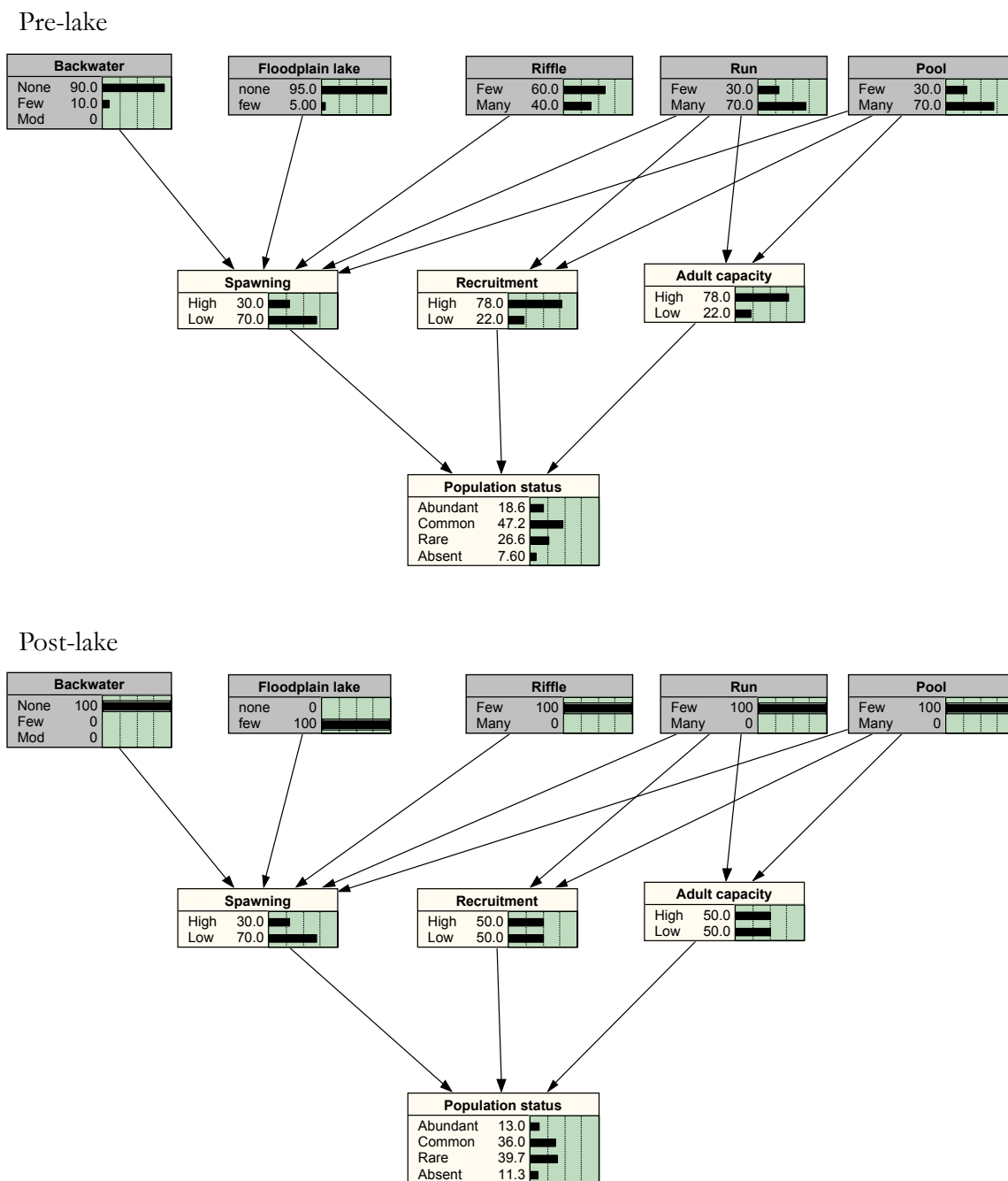
**Table 4.7.** General fish BBN model population probabilities. Leaf River and post-impoundment BBN model abundance probabilities and the change between the two.

BBN population probabilities: general fish

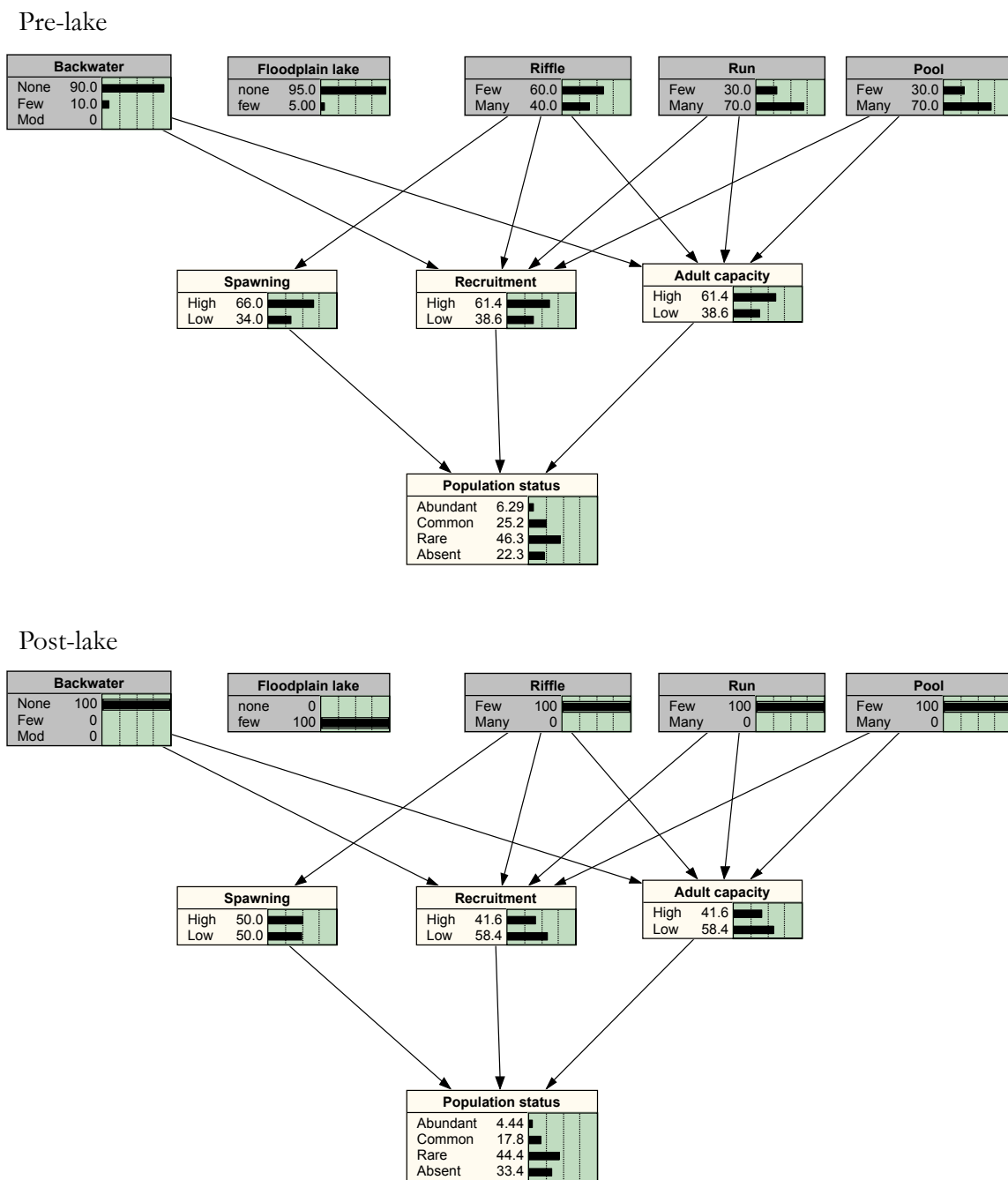
Fish	Current Abundance	Abundance Category	Leaf River model probabilities	Post-impoundment model probabilities	Change
Creek chubsucker	Abundant	Abundant	39.9	51.3	11.4
		Common	10	10	0
		Rare	35.3	27.3	-8
		Absent	14.7	11.4	-3.3
Black madtom	Common	Abundant	18.6	13	-5.6
		Common	47.2	36	-11.2
		Rare	26.6	39.7	13.1
		Absent	7.6	11.3	3.7
Dusky darter	Rare	Abundant	6.29	4.44	-1.85
		Common	25.2	17.8	-7.4
		Rare	46.3	44.8	-1.5
		Absent	22.3	33.4	11.1



**Figure 4.8.** Creek chubsucker (general habitat partition, abundant abundance) BBN models. Pre- and post-lake development habitat occurrence probabilities.



**Figure 4.9.** Black madtom (general habitat partition, common abundance) BBN models. Pre- and post-lake development habitat occurrence probabilities.



**Figure 4.10.** Dusky darter (general habitat partition, rare abundance) BBN models. Pre- and post-lake development habitat occurrence probabilities.

#### 4.3.4 – Riverine Fish

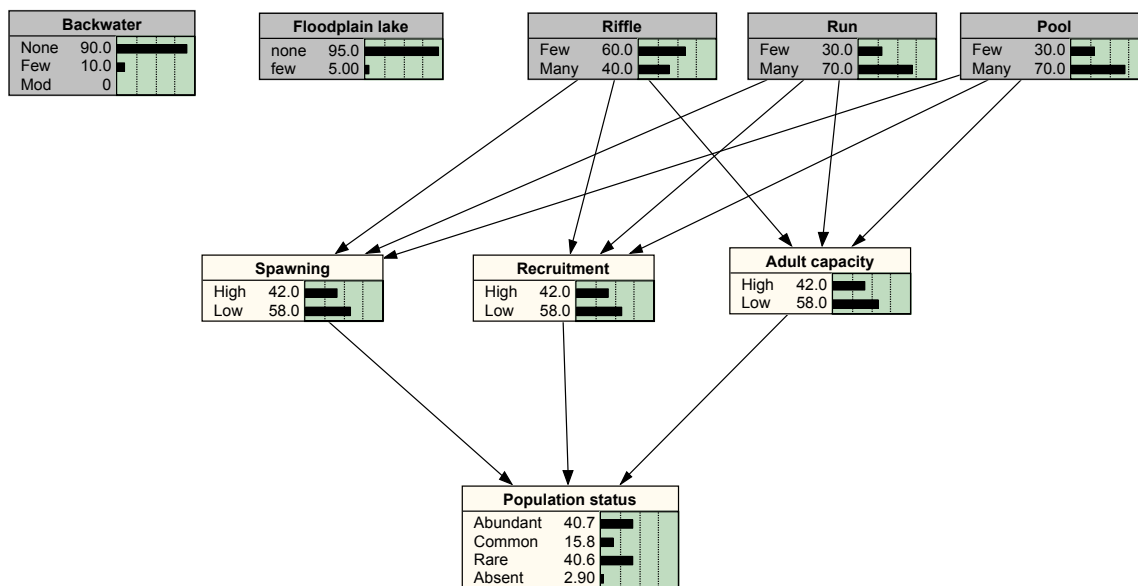
The clear chub (Figure 4.11), silverjaw minnow (Figure 4.12), and the brighteye darter (Figure 4.13), all declined in abundance after impoundment (Table 4.8). As shown in Table 4.8, the presently abundant clear chub (Figure 4.11) was 10.2% less likely to be abundant and 8.4% more likely to be rare following impoundment. The silverjaw minnow (Figure 4.12), a common fish with Leaf River habitat configurations, exhibited greater decline in population probabilities and was 7% less likely to be abundant and 16.3% more likely to be rare following impoundment. The rare brighteye darter (Figure 4.13) declined in abundance and was 1.84% less likely to be abundant and 1.9% more likely to be rare following impoundment (Table 4.8).

**Table 4.8.** Riverine fish BBN model population probabilities. Leaf River and post-impoundment BBN model abundance probabilities and the change between the two

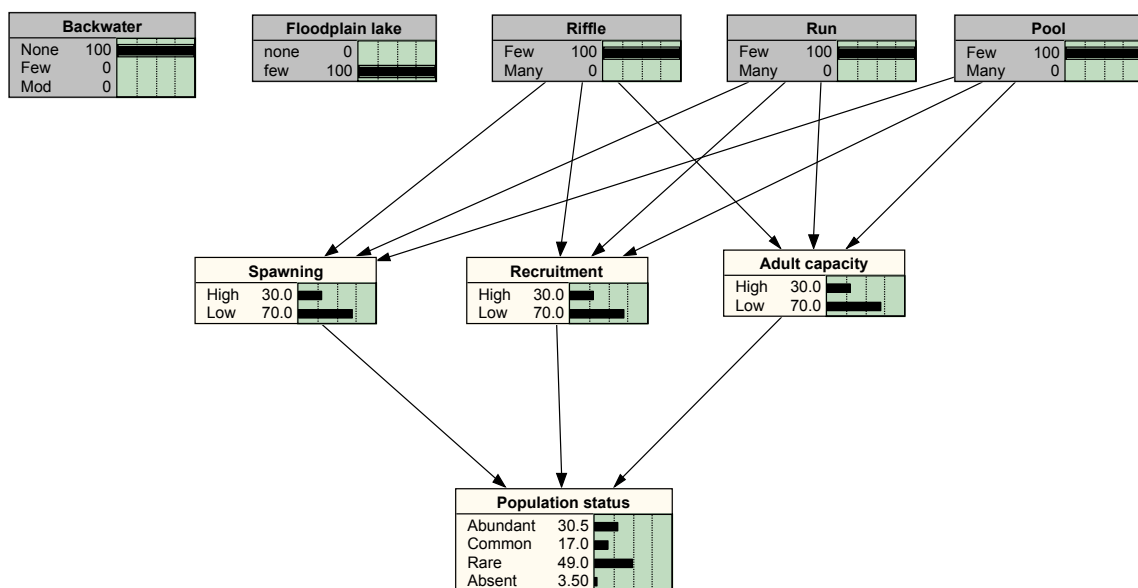
BBN population probabilities: Riverine fish

Fish	Current Abundance	Abundance Category	Leaf River model probabilities	Post-impoundment model probabilities	Change
Clear chub	Abundant	Abundant	40.7	30.5	-10.2
		Common	15.8	17	1.2
		Rare	40.6	49	8.4
		Absent	2.9	3.5	0.6
Silverjaw minnow	Common	Abundant	22	15	-7
		Common	54	40	-14
		Rare	18.7	35	16.3
		Absent	5.33	10	4.67
Brighteye darter	Rare	Abundant	6.17	4.33	-1.84
		Common	24.7	17.3	-7.4
		Rare	46.2	44.3	-1.9
		Absent	23	34	11

Pre-lake

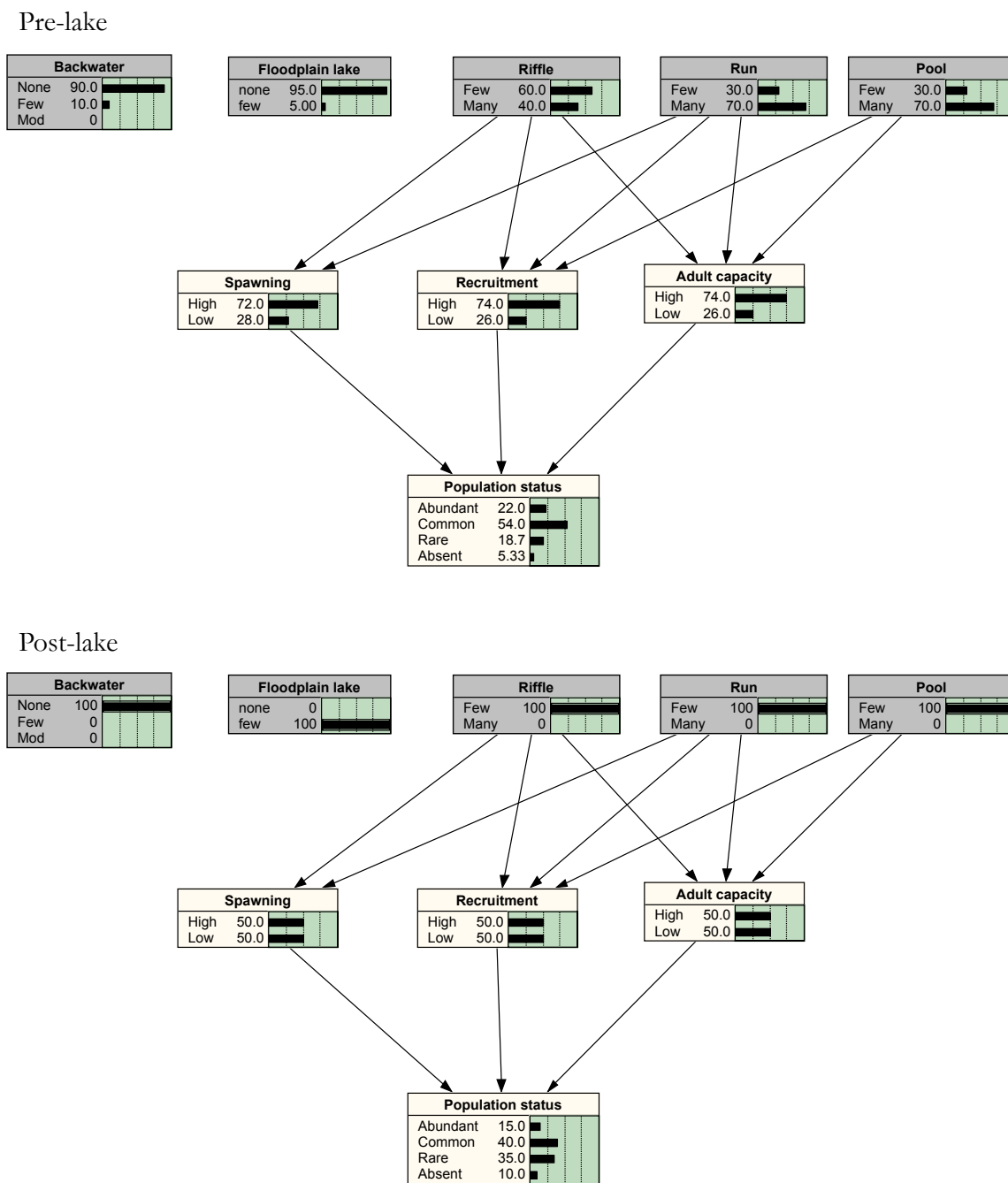


Post-lake



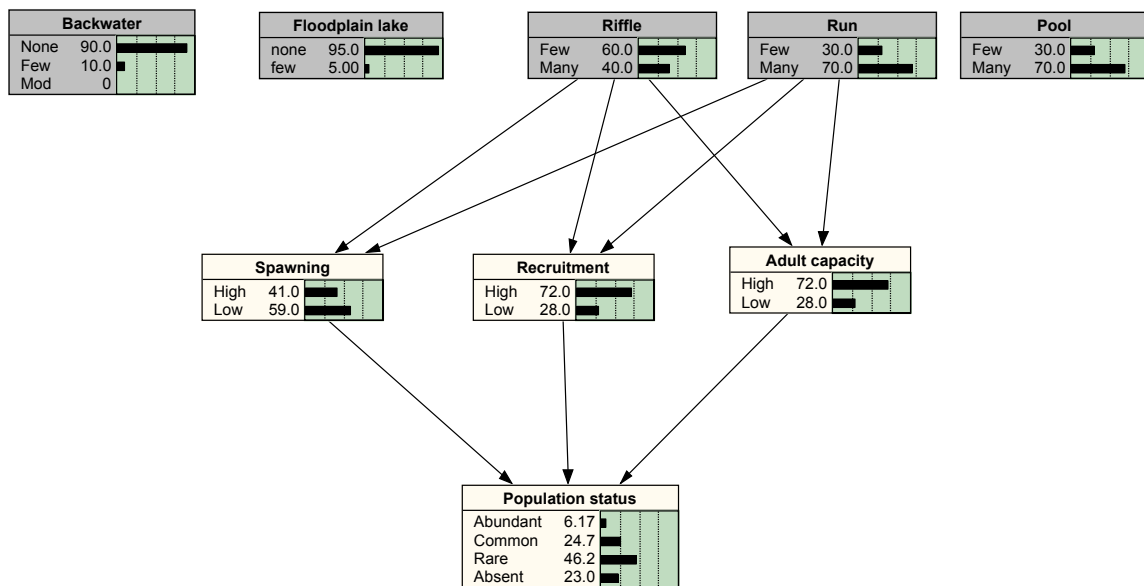
**Figure 4.11.** Clear chub (riverine habitat partition, abundant abundance) BBN models. Pre- and post-lake development habitat occurrence probabilities.



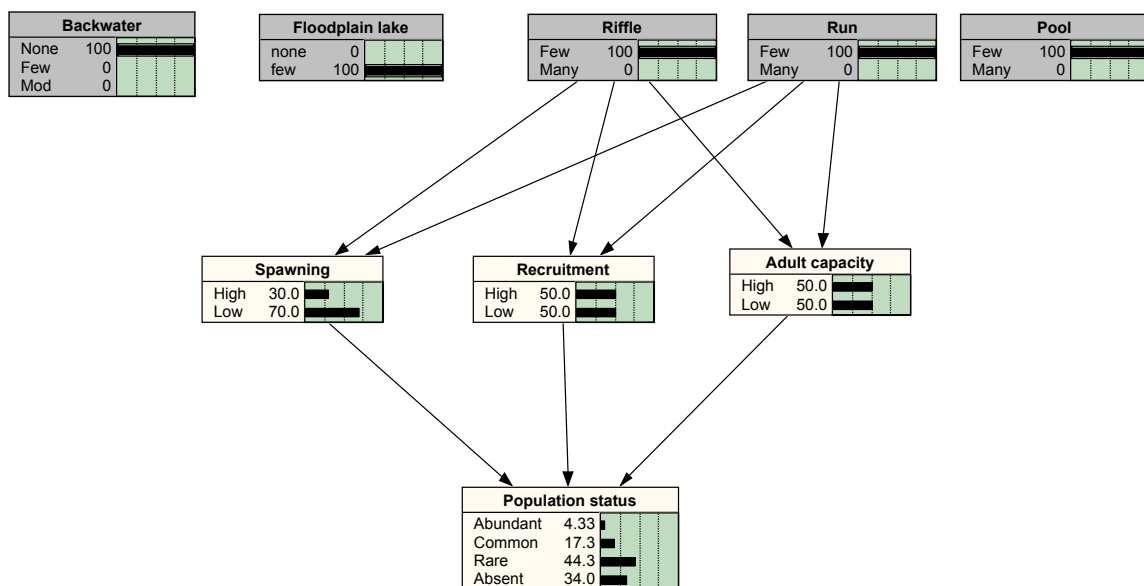


**Figure 4.12.** Silverjaw minnow (riverine habitat partition, common abundance) BBN models. Pre- and post-lake development habitat occurrence probabilities.

Pre-lake



Post-lake



**Figure 4.13.** Brighteye darter (riverine habitat partition, rare abundance) BBN models. Pre- and post-lake development habitat occurrence probabilities.

### 4.3.5 – Backwater Fish

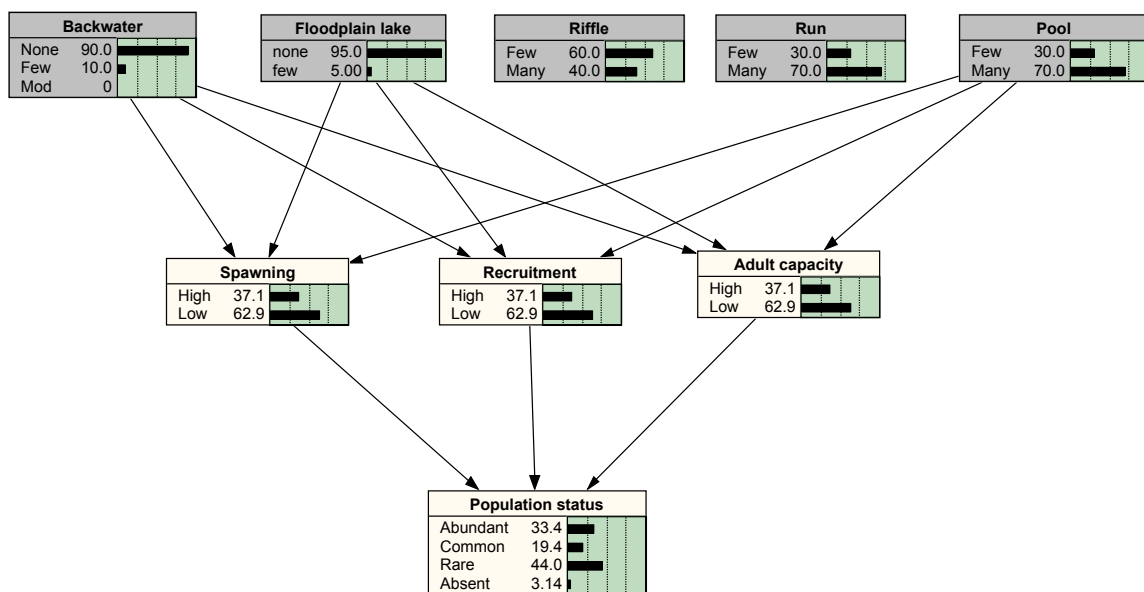
The bluegill (Figure 4.14), black bullhead (Figure 4.15), and the white crappie (Figure 4.16), all backwater fish, increased in abundance with post-impoundment habitat configurations (Table 4.9). As shown in Table 4.9, the presently abundant bluegill (Figure 4.14) was 23.6% more likely to be abundant and 18.3% less likely to be rare following impoundment. The black bullhead (Figure 4.15), a common fish with Leaf River habitat configurations, was 4.4% more likely to be abundant and 10.3% less likely to be rare following impoundment. The white crappie (Figure 4.16) also showed increased in abundance and was 3.12% more likely to be abundant and 2.6% more likely to be rare following impoundment (Table 4.9).

**Table 4.9.** Backwater fish BBN model population probabilities. Leaf River and post-impoundment BBN model abundance probabilities and the change between the two.

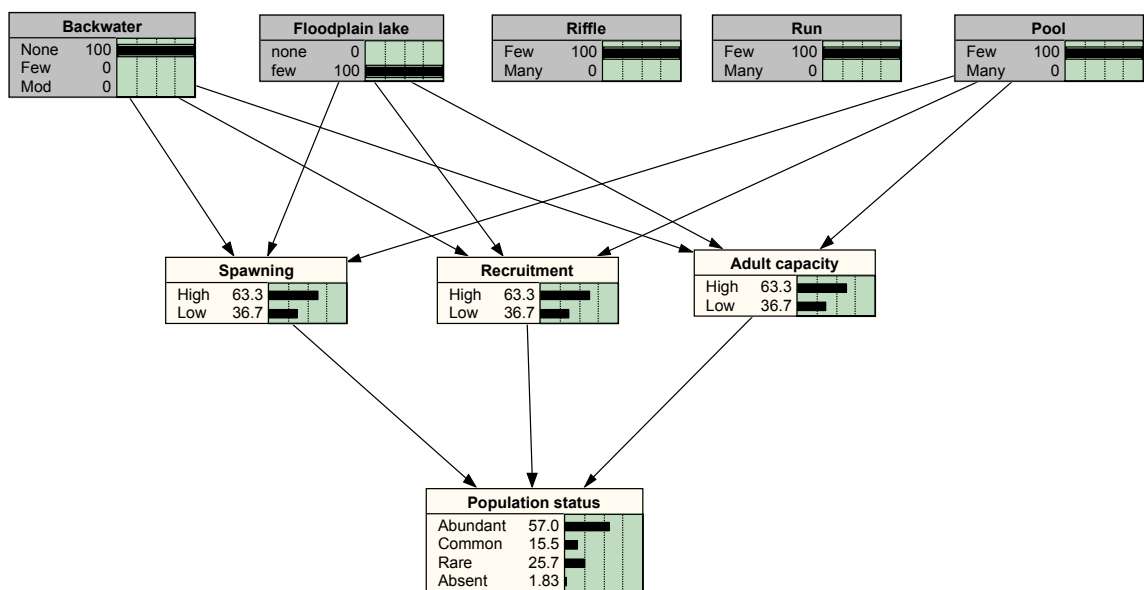
BBN population probabilities: Backwater fish

Fish	Current Abundance	Abundance Category	Leaf River model probabilities	Post-impoundment model probabilities	Change
Bluegill	Abundant	Abundant	33.4	57	23.6
		Common	19.4	15.5	-3.9
		Rare	44	25.7	-18.3
		Absent	3.14	1.83	-1.31
Blackbull head	Common	Abundant	10.6	15	4.4
		Common	31.2	40	8.8
		Rare	45.3	35	-10.3
		Absent	12.9	10	-2.9
White crappie	Rare	Abundant	3.21	6.33	3.12
		Common	14.9	25.3	10.4
		Rare	43.7	46.3	2.6
		Absent	32.7	22	-10.7

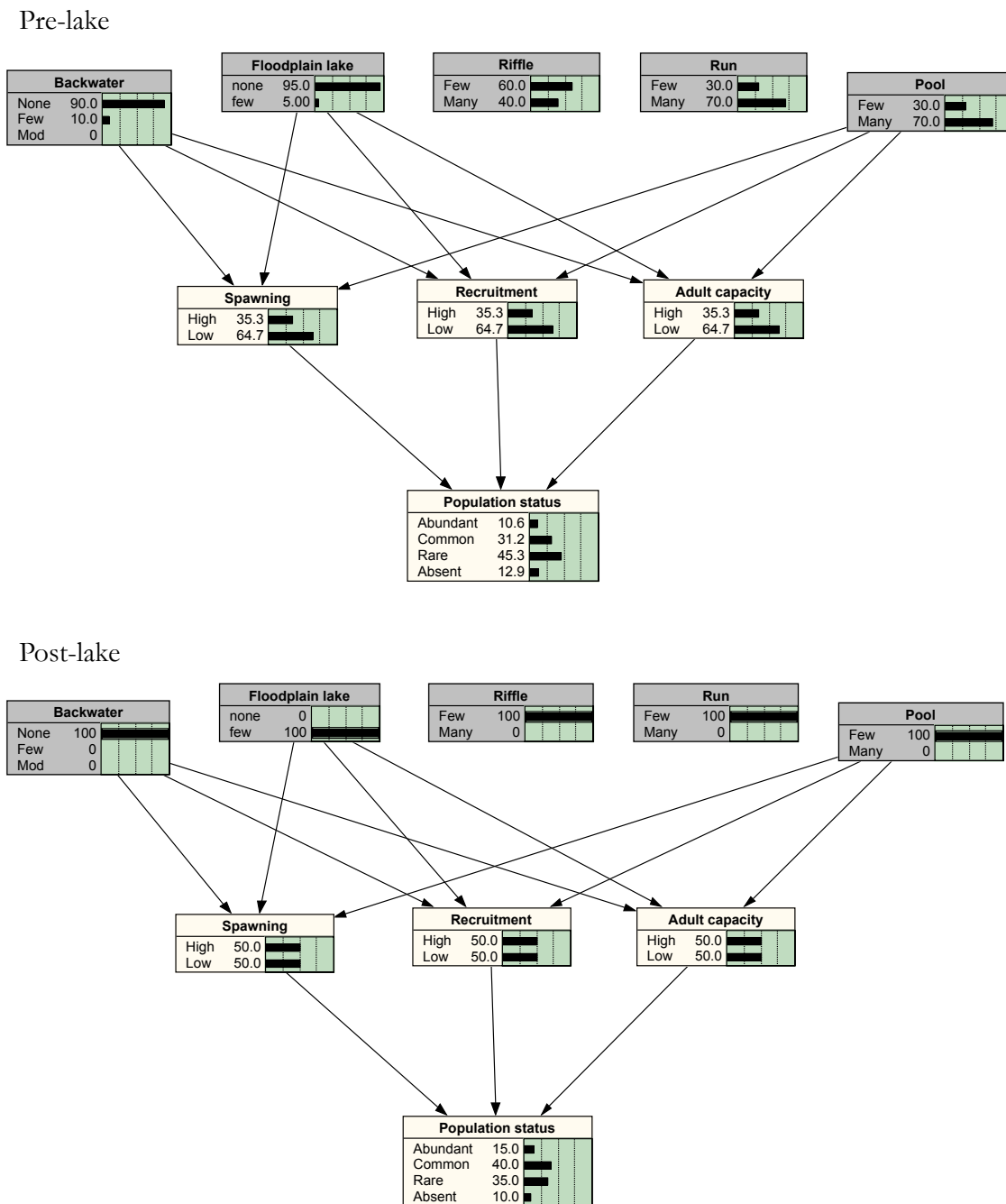
Pre-lake



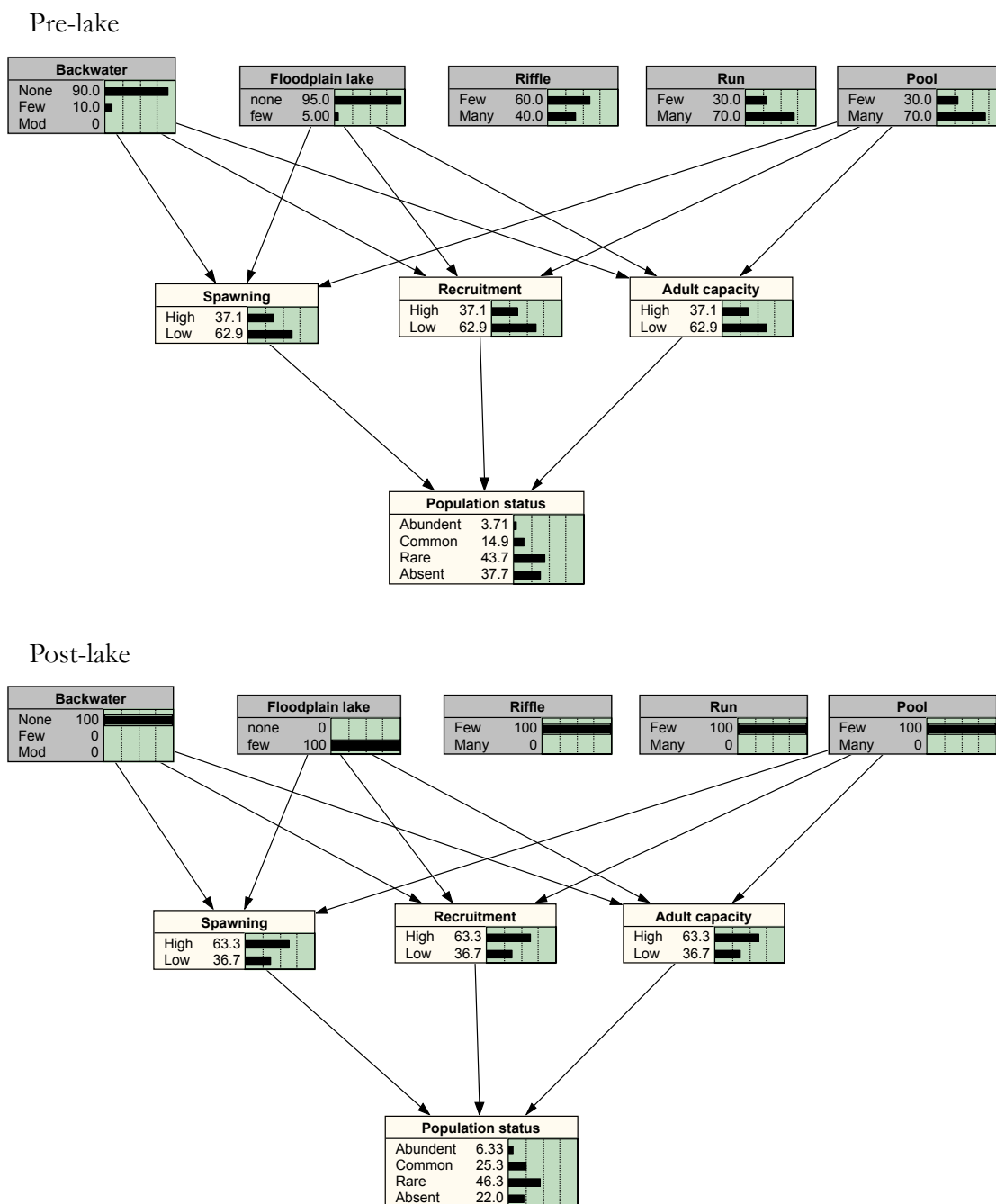
Post-lake



**Figure 4.14.** Bluegill (Backwater habitat partition, abundant abundance) BBN models. Pre- and post-lake development habitat occurrence probabilities.



**Figure 4.15.** Black bullhead (Backwater habitat partition, common abundance) BBN models. Pre- and post-lake development habitat occurrence probabilities.



**Figure 4.16.** White crappie (Backwater habitat partition, rare abundance) BBN models. Pre- and post-lake development habitat occurrence probabilities.

#### 4.3.6 – Aquatic summation

The general fish showed both decline and increases in abundance probabilities, all riverine fish declined in population abundance due to the loss of almost all riverine habitats above the control structure, and all backwater fish showed an increase in abundance probabilities due to the reservoir and subsequent impoundment “backwater” type habitats.

## CHAPTER V

### PROCESS

This chapter includes the step-by-step process associated with the creation and implementation of the SDSS. Detailed descriptions are included here with a more condensed version in Appendix F. The overall process is shown in the SDSS flowchart of Figure 5.1 with a more detailed view of the GIS, BBN, and GAP sections in Figures 5.2, 5.3, and 5.4 respectively. Each step is shown below with the corresponding flowchart reference in parenthesis.

Note that the process order described below is not absolute. It would also be possible to start with processing the MS-GAP data, or constructing the pre-development BBN model. Flexibility is one of the characteristics of a SDSS, and this one would allow the planner or scientist the ability to begin in one of the three subject areas as data becomes available.

#### 5.1 – GIS (Figure 5.2)

Step 1 (GIS1 and 2): Lake site digitization.

Using ArcGIS Spatial Analyst™, a hypothetical test site was located on Ichusa Creek with a surface elevation of 400' MSL using the Smith County DEM. To do this, the DEM was contoured (GIS1) and a control structure location and height determined. The contour associated with the determined lake elevation was digitized (GIS2) to produce the lake polygon.

Step 2 (GIS3): Lake site aquatic habitat incorporated

An aquatic habitat survey was conducted for the area on Ichusa Creek above the



# SDSS

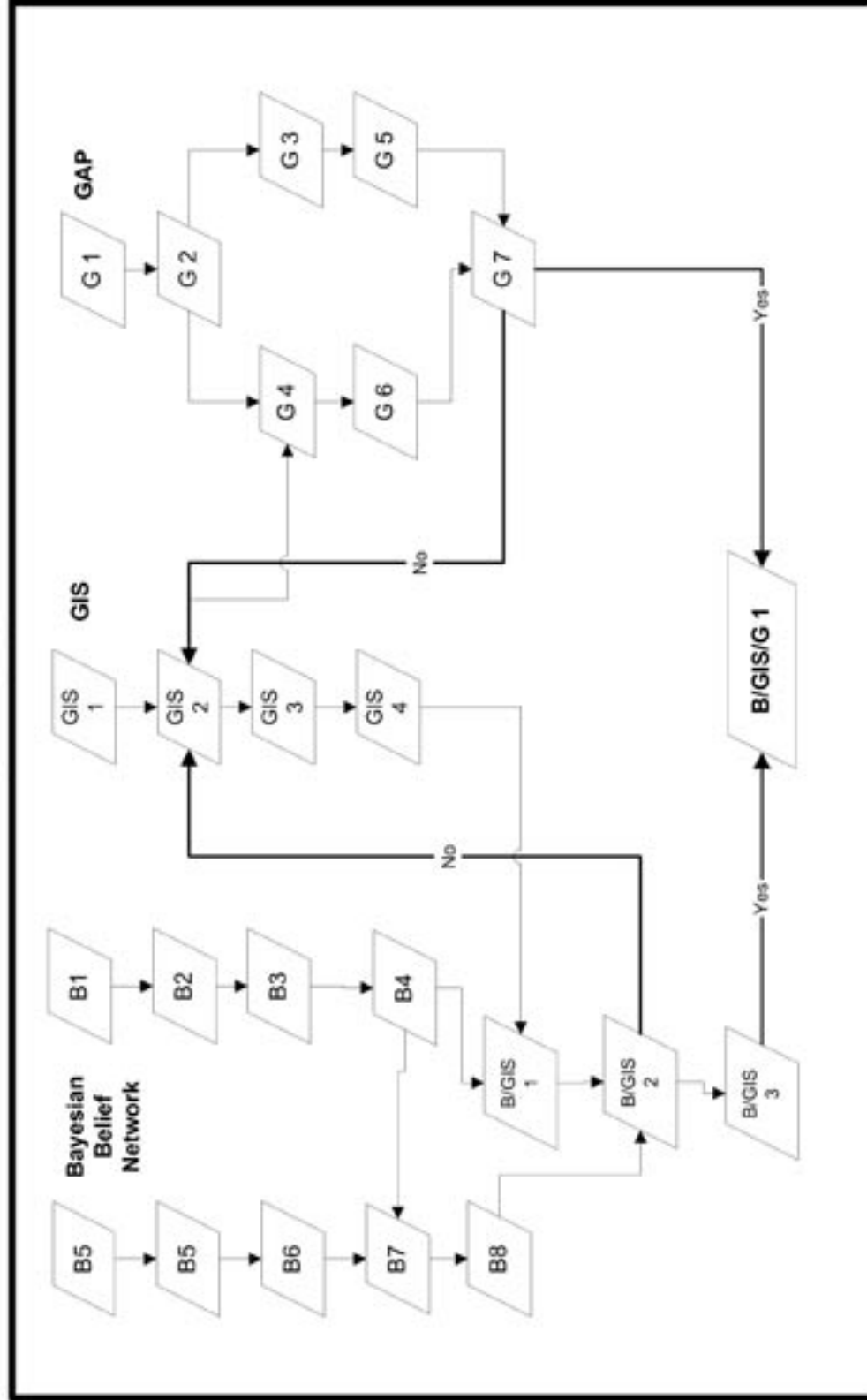


Figure 5.1. SDSS flow chart. See Chapter V for description.

hypothetical control structure described in Step 1. This survey included the inventorying of aquatic habitats over four 200 meter sample locations into five habitat categories: backwaters, floodplain lakes, riffles, runs, and pools.

Step 3 (GIS 4): Aquatic habitat quantification

The habitat categories identified and inventoried in Step 2 were input into excel and quantified using Microsoft Excel™. Within Excel™, the numbers of affected and unaffected habitats were calculated. These values were used as input for the percentages of habitat in the parent stage of the model.

## **5.2 – BBN (Figure 5.3)**

Step 4 (B1): Fish survey data acquisition.

Fish survey data was acquired from the Mississippi Forest Service. The survey took place from 2000 – 2004 across all streams within the National Forest of Mississippi.

Steps 5 (B2): Fish survey data preparation.

The study site for this project was the Leaf River System within the Bienville National Forest, Smith County Mississippi. The fish survey completed for the Mississippi National Forest Service inventoried fish in streams located within the bounds of Mississippi's National Forest. Using Microsoft Excel, the survey was subset to the study site and produced a complete list of fish in the Leaf River system within the Smith County Bienville National Forest.

Step 6 (B3): Life stage/habitat use matrix construction.

As described in Section 3.2.2, a matrix was constructed for each fish found to occur in the study site. Literature was researched to understand which habitats (backwaters, floodplain lakes, riffles, run, and pools) where used throughout the spawning, juvenile, and adult life stages.

Step 7 (B4): Baseline BBN model construction.

Using Netica 1.1.2™, models were built for each species based on linking habitats,

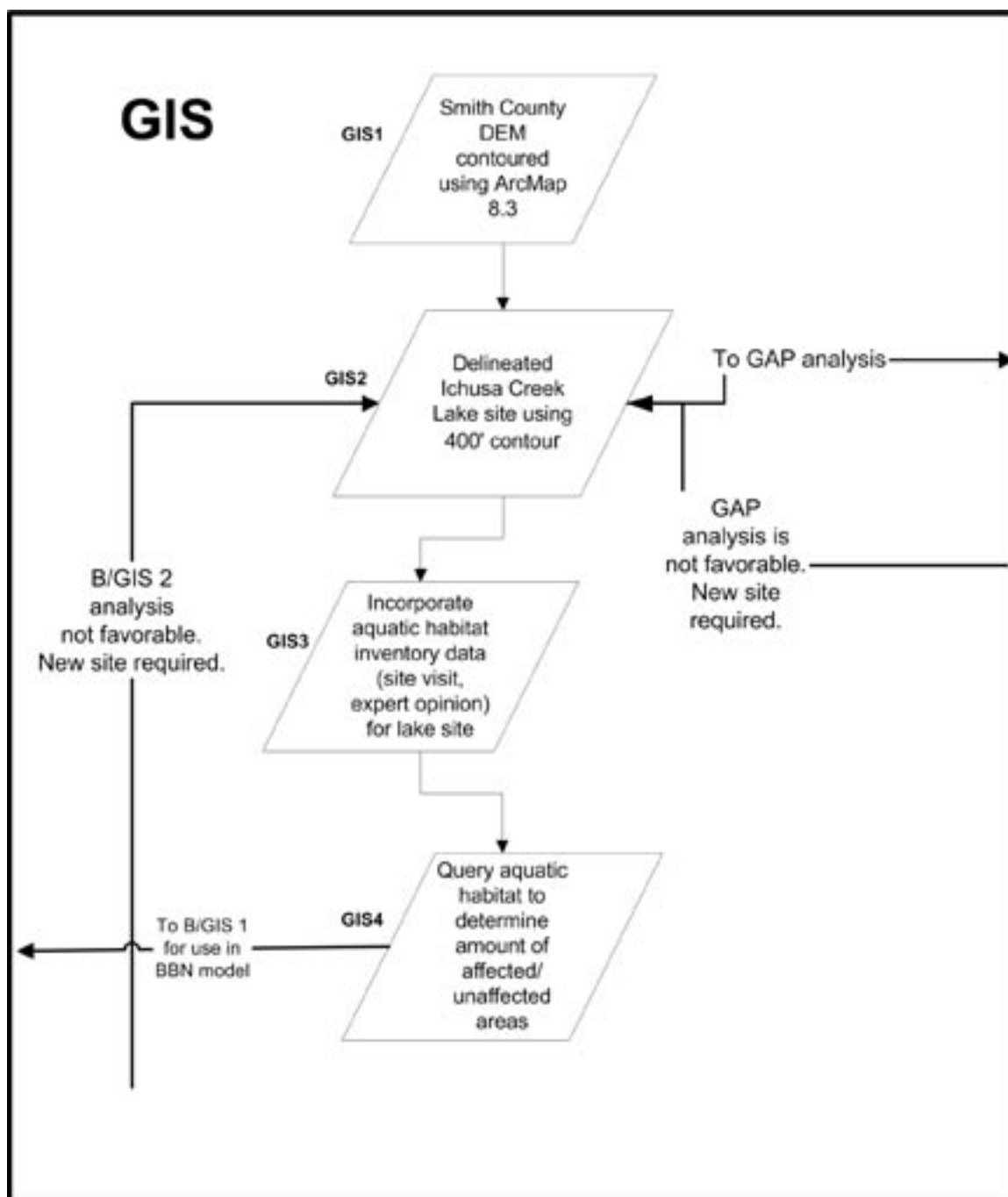


Figure 5.2. GIS flow chart. See Chapter V for description.

life stages, and population status. This model construction also included the calculation of probabilities within Microsoft Excel™ spreadsheets using the life stage/habitat use matrix constructed in Step 6. The calculations were implemented into the BBN model as probabilities associated with each state.

Step 8 (B5, B6, and B7): Leaf River BBN model construction.

To apply this BBN model specifically to the study area, a quantification of available aquatic habitats throughout the study area was needed. A complete habitat survey was not available and out of the scope of this project, however stream data was provided with the fish survey from the Mississippi National Forest service and site visits (B5) revealed that the Leaf River system is dominated with run and pool habitats with very few riffles, floodplain lakes, and backwaters. With this understanding (B6), habitat states of the BBN model constructed in Step 7 were quantified with current habitat occurrence probabilities and the model was run within Netica™ (B7) to calculate population probabilities given current habitat configurations (B8).

Step 9 (B/GIS 1): Test site BBN model construction.

To understand the effects of an impoundment on fish within and above the impoundment, the base BBN models from step 7 were populated with percentages indicative of Ichusa Creek aquatic habitat occurrence within the impoundment site (Step 3). These include all habitats of Ichusa Creek above the impoundments control structure. For each habitat, the number of remaining or unaffected habitats was divided by the total number of habitats. This provided a percentage of available habitats above the control structure. These numbers were input into the base BBN model as variable of each habitat state from step 7 and the model was run to calculate population probabilities for fish located above the control structure.

Step 10 (B/GIS 2): Leaf River/test site BBN model comparison.

A direct comparison between the Leaf River BBN and the test site BBN population

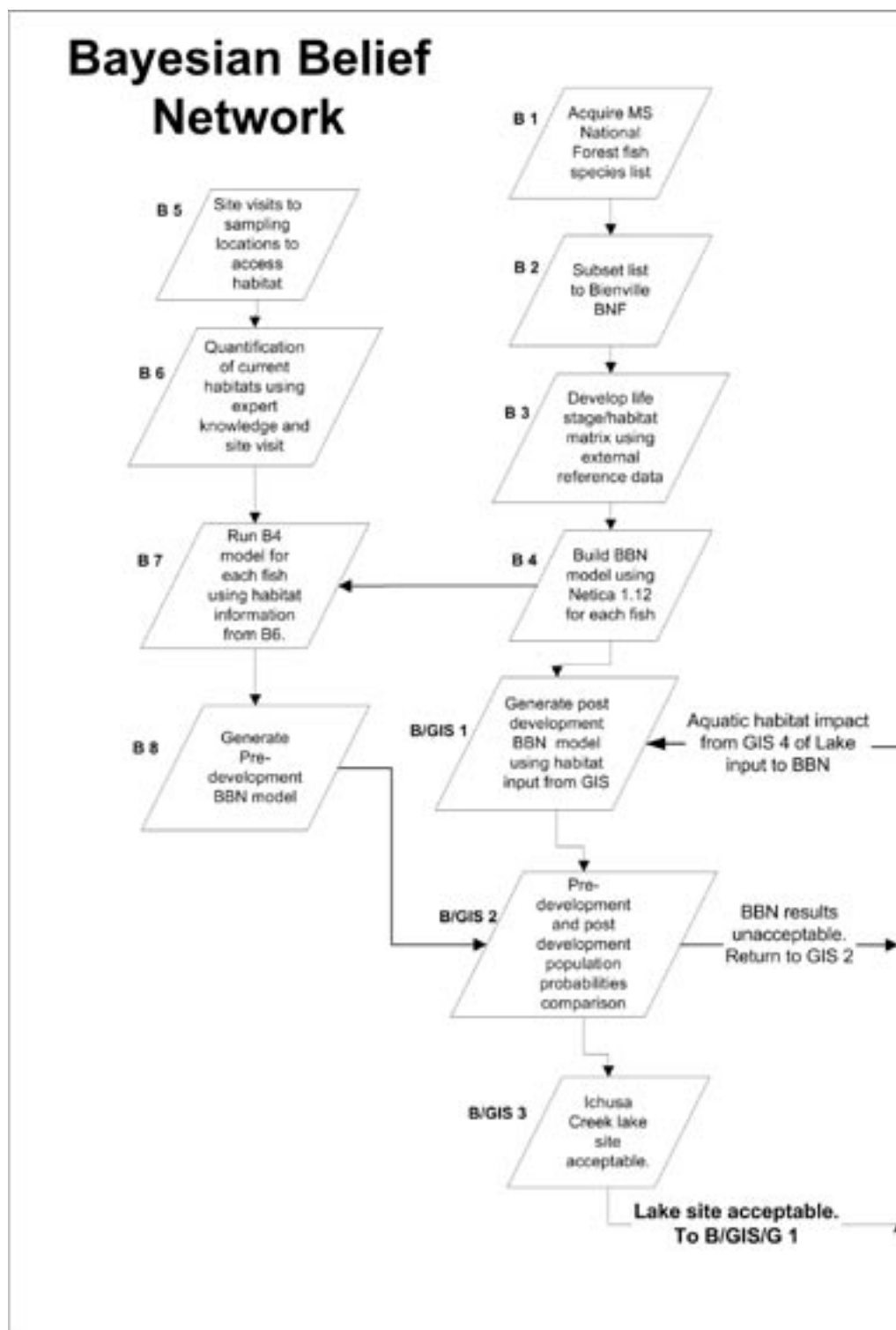


Figure 5.3. BBN flow chart. See Chapter V for description.

probabilities provided an understanding of the impacts of this impoundment on indigenous fish populations. For the sake of this project, nine fish were chosen for comparison to test the model. As described in Section 3.2.2, fish were classified based upon current population status (Abundant, Common, Rare) and habitat needs, backwater, riverine, or general (using both riverine and backwater), which were based on the life stage/habitat use matrix. An abundant, a common, and a rare species were randomly selected from each of the backwater, riverine and general classifications. For these nine fish population probabilities were compared to determine the impacts of the impoundment on fish of varying abundance and habitat needs.

If the results from step 10 reveal unacceptable results (per the model user), it is possible to go back to Step 2, select another lake site, and re-run the model based on another location. This process can continue until a suitable site is found.

Step 11 (B/GIS 3): Lake site is found acceptable.

Given accepted population probabilities that are determined by the model user, the lake location is accepted based on aquatic information.

### **5.3 – GAP (Figure 5.4)**

Step 12 (G1): Gap Analysis Program data acquisition.

The Mississippi Gap Analysis Program (GAP) data was completed and released to the public in 2003. It is available through the Mississippi Fish and Wildlife Research Unit at Mississippi State University.

Step 13 (G2): GAP data preparation.

To reduce file size, the Mississippi GAP data is subset to Smith County, Mississippi using Erdas Imagine™. With Smith County as the area of interest (AOI), the Mississippi landcover and species richness data layers were subset to Smith County.

Step 14 (G3 and G4): Bienville National Forest and lake site subset.

The Smith County GAP data was subset to the Bienville National Forest(G3) and

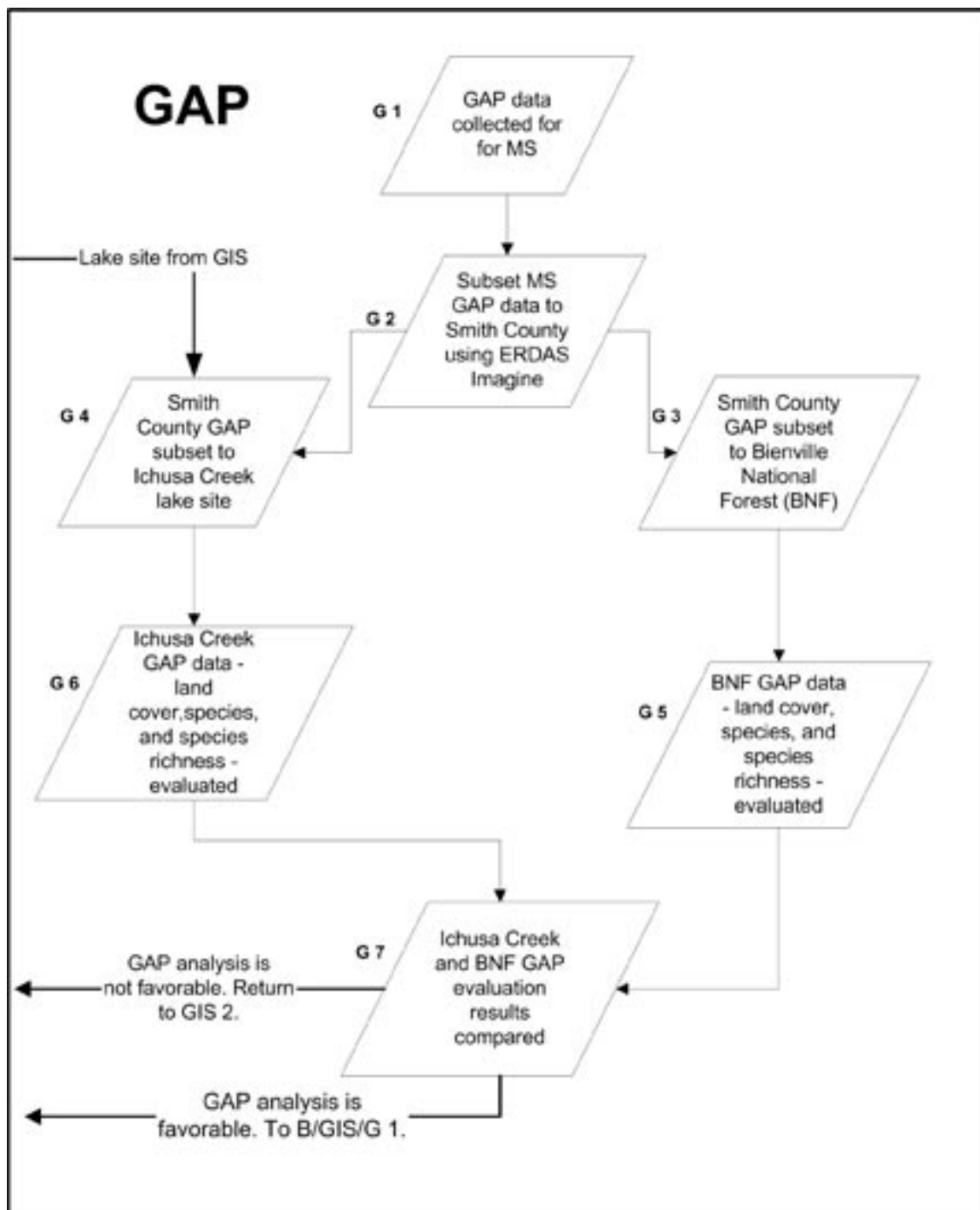


Figure 5.4. GAP flow chart. See Chapter V for description.

the test lake site developed in Step 1 (G4) using the same process of Step 13. These subsets include landcover and herpetiles, bird, and mammal species richness.

Step 15 (G5 and G6): GAP subset calculations.

The attribute table for each subset was exported to Microsoft Excel™. For both sites (Bienville National Forest and the test site) landcovers, pixel counts were converted to hectares and acreages and the weighted means for each species richness data layer was calculated.

Step 16 (G7): GAP data analysis.

The subset calculations from Step 15 were used to calculate the percentage of landcover and species richness that would be lost with the development of the impoundment. The area of each test site landcover type was divided by the same landcovers from the Bienville National Forest. These percentages were compared with the lake site/Bienville National Forest land area percentage to determine if a large percentage or all of any one landcover would be lost. The species richness weighted means were also compared to determine if the lake site had uncharacteristically high species richness.

#### **5.4 Conclusions**

After the analysis of the GAP data, if the model user determines the site is not acceptable, it is possible to return to step 1 to determine another lake location. The GAP model can then be re-run until an acceptable location is determined. If unusually high species richness does not occur within the site, there is no loss of habitat utilized by threatened or endangered species and the percentage of landcover loss is acceptable, the lake location is accepted based on terrestrial information. A site is determined to be acceptable once predefined criteria are validated by the SDSS toolbox using Netica™ and ArcGIS™.



## CHAPTER IV

### CONCLUSION

#### 6.1 – Introduction

The Leaf River system located within the Bienville National Forest in Smith County, Mississippi was the study site and the SDSS was constructed in order to assess the impacts of a water impoundment on terrestrial and aquatic ecosystems. Terrestrial data was provided by the Mississippi Gap Analysis Program (GAP) while aquatic data was garnered from the Mississippi National Forest Service.

#### 6.2 - GIS

The GIS proved valuable for collecting, organizing, and managing data, tasks for which it is well suited. A GIS is especially useful when organizing data of different formats. GAP data is stored in a raster format, while the outline of the lake was created as a vector file. The GPS data collected to quantify the habitat loss created by the hypothetical lake was a series of points, lines, and polygons. The GIS allowed for the collection and organization of the data in a format that is useable for many different operations. In areas such as landscape planning, where decisions are made about issues with complex physical and social implications, a GIS presents the user with an interface to simplify the process. It is this interface and analytical ability that offers the best solution for the integration of diverse data types and models, such as BBN and GAP (Taylor 1999).

The major drawbacks to a GIS are cost and complexity. ArcGIS, which is developed and marketed by Environmental Systems Research Institute (ESRI), is a series

of applications marketed as a “toolbox”. The users can add and subtract tools as needed. Additional specialized tools can be added that are called extensions. As the user expands his/her toolbox the level of expertise and knowledge also rises. ArcGIS 8.3 is a very complicated set of tools that requires substantial training and experience. Users can customize, or re-program, the GIS interface to “simplify” access to applications, but this requires an even higher level of knowledge. If links are to be created that seamlessly transfer outputs from one application such as GPS to ArcGIS Spatial Analyst some additional programming will probably be required.

### **6.3 - BBN**

The majority of the work for the BBN was conducted early in the process with the construction of individual models for each fish species found within the study area. The BBN was constructed so that probabilities of population status could be calculated given particular habitat conditions. The BBN modeling was designed to represent both the entire Leaf River system and the subset delineated by the hypothetical lake site.

Two BBN models were constructed for each fish. The first habitat percentages indicative of the current Leaf River system and the other model was run with habitat percentages representative of habitats available with the development of the impoundment. With these two models it was possible to calculate and compare population abundance probabilities for each fish given each habitat configuration.

A BBN is a very powerful, very complex system with both positive and negative attributes. A BBN must be constructed by experts from fields relative to the subject area since extensive background experience is required. Some work has been done using BBNs in natural resource management, but the majority of the work has focused on health care issues. More work is needed using BBN within fisheries science to build up a body on knowledge in areas similar to this research project.

Peer reviews should be conducted to assess the assumptions made by the model designer and review inputs. The model designed for this project was very subjective in both how the data was assessed and the parent and child stages were configured for the analysis. Conflicts exist between different sources of habitat data. The best way to resolve these issues is through peer review of BBN model data.

Constructing the model was time consuming. This may deter the use of this model in planning situations where these resources are not available, but the amount of energy required in making this model a success is relatively miniscule to the amount of information produced by doing so and the lack of plausible alternatives.

The BBN associated with this study originally had no spatial definition other than the fact that the five habitats were specific to the Leaf River system. GPS technology was used to delineate the aquatic habitat. Through the use of GIS software it was possible to specifically relate the BBN aquatic information to the impoundment site. With the input of specific habitat numbers from the hypothetical impoundment site, the BBN was able to update the population abundance probabilities therefore showcasing a more specific impact on fish of the study area.

#### **6.4 - GAP**

GAP data was used to assess the impacts of the impoundment on landcovers, terrestrial species, and species richness. Landcovers and mean species richness numbers were compared between the test impoundment site and the Bienville National Forest. Using the GAP species list, it was possible to produce a list of threatened and endangered species which utilize habitats within the test site.

Anyone with a working knowledge of ArcGIS™ can easily work with the GAP datasets. It is standardized and nationally accepted, easy to use with standard GIS tools and free to the public. The only drawback experienced was the dating of the data. GAP data for

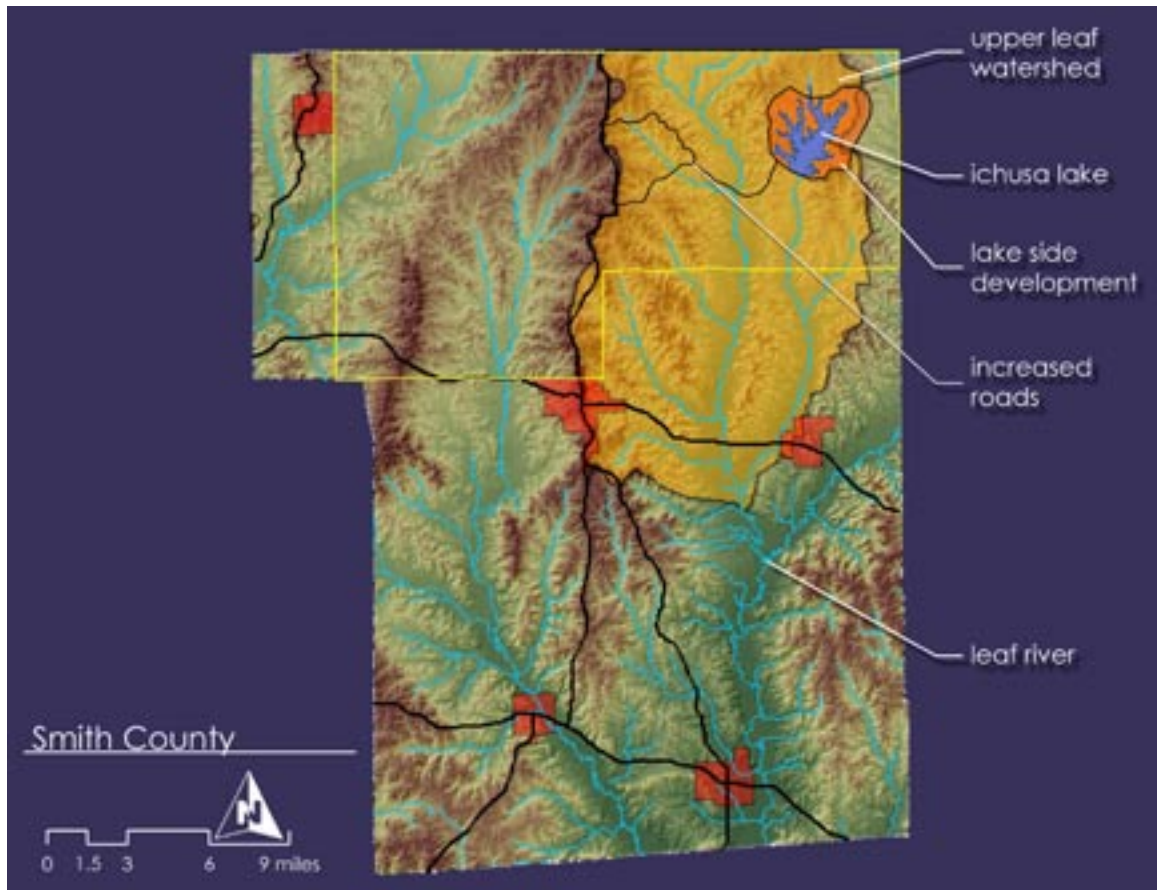
this project was based on LandSat imagery from the mid-1990s and a lot can change in that amount of time, however because this project was based within the Bienville National Forest, most of the landcovers have not changed in that amount of time.

## 6.5 – SDSS

As mentioned earlier, Dymond (2004) states that a SDSS allows the operator to integrate diverse amounts of data, and supply modeling to address spatially explicit problems. SDSSs often use the GIS for the interface to link with other applications. That was the original intent for this project. MS-GAP data, which is spatial in nature, was to be used to assess the impact of the lake on of terrestrial vertebrates and land cover types. The BBN, which is non-spatial in nature, was used to assess the lake's impact on aquatic species. ArcGIS was to serve as the interface to the two different data types. The SDSS is not a specific process or application. It is more of an approach to the integration as defined by Dymond.

Both the GAP data and the BBN model outputs are independent, complex and produce diverse results which can aid planners in their inventories and analysis of natural resources. Each succeeded in providing assessments of the impacts this impoundment may have on terrestrial and aquatic ecosystems of the study area. The steps outlined in the Process Chapter clearly delineate the methodology followed throughout this research project. This approach meets the definition of an SDSS except for the data integration within a common interface. Because of the different data types associated with the BBN and GAP, the integration within a common interface requires the expertise of a computer programmer.

The BBN and GAP data was not integrated through a common interface. Because of each tool successfully working independently a complete integration was not needed. ArcGIS 8.3 provided the interface through which the GAP data was analyzed and the aquatic habitat survey for the BBN was quantified.



**Figure 6.1.** Smith County, Upper Leaf River watershed, Ichusa Lake and other potential developments.

### 6.6 – Future Research

This study only assessed the impacts associated with the footprint of the impoundment. However, in reality urbanization associated with impoundments such as this one could pose a greater risk to terrestrial and aquatic ecosystems than that of the impoundment itself. Residential, commercial and industrial developments (Figure 6.1) have the potential to cause increased runoff, sediment loads, and nutrients thus decreasing water quality. As with the impoundment site, effected landcovers can be calculated as well as the impacts caused by increased roads and transmission corridors. These often fragment habitats and landcovers and with GAP data it is possible to recognize areas of fragmentation and provide possible

connection corridors. Not only will increased amounts of landcovers be affected, but detrimental aquatic variables, other than habitat loss are introduced.

Similar to the terrestrial analysis, the BBN only assessed the impacts on fishes above the control structure of the impoundment. It should be noted that with the fragmentation of aquatic habitats caused by the control structure, fishes below the control structure will also be affected. In order to provide more specific predictions in future projects, BBN models should be constructed in a manner so that variables other than habitat numbers can be included (i.e. water quality, watershed inputs, etc.).

As mentioned in the literature review, GAP data cannot take the place of extensive site inventories. No truer is the case than with the possible occurrence of threatened and endangered species that are shown to occur within the site. GAP data provides the locations of possible occurrence for these species, but an extensive inventory should be conducted in order to verify the existence of these important species, so that any habitat associated with an imperiled species should be conserved and any alteration that fragments an essential habitat should be avoided.

Several areas in which to build upon this SDSS exist. All possible residential, commercial, industrial, transportation, and transmission developments, apart from the footprint of one impoundment should be included, so that a more accurate depiction of the impacts posed by a true “suite” of developments can be modeled. Due to the time lapse since GAP data was classified, a re-classification may be needed in order to provide accurate data. In areas such as the one used for this study where endangered species are known to occur, the locations of endangered or threatened species populations should be delineated using a GPS and input into a GIS so that the populations and all habitats associated with those species can be avoided. In order to make this SDSS more user friendly and one that planners can readily access and use, future research should be aimed at a true integration of GAP and a BBN.

GAP and a BBN work well together, although not in a fashion in which one button

can be pressed and the tools run simultaneously. The SDSS successfully provided assessments for both terrestrial and aquatic environments. Anyone familiar with a GIS can utilize GAP data; because of this and the fact that it is public domain, planners have the potential to utilize this valuable data set to help deter developments from infringing on areas of high biodiversity. BBNs are complex and require expert knowledge to validate each model and data. However users do have the ability to construct each model specific to their needs. This compounded with a GIS gives planners a tool that allows natural environments to become an integral part of the planning process.

## LITERATURE CITED

- Aerts, Jeroen C J H, Gerard B M Heuvelink, and Michael F Goodchild. "Accounting for Spatial Uncertainty in Optimization with Spatial Decision Support Systems." Transactions in GIS 7.2 (2003): 211-30.
- Armstrong, M. P., P. J. Densham, and G. Rushton. "Architecture for a Microcomputer Based Spatial Decision Support System." Proceedings of the 2nd International Symposium on Spatial Data Handling. Williamsville: International Geographical Union, 1986. 120-31.
- Becker, George C. Fishes of Wisconsin. Madison: University of Wisconsin Press, 1983.
- Britannica, Encyclopædia. 2004. Encyclopædia Britannica Premium Service. Available: <http://www.britannica.com/eb/article?eu=115242>. June 9, 2004.
- Bryan, Brett A. "Physical Environmental Modeling, Visualization and Query for Supporting Landscape Planning Decisions." Landscape and Urban Planning 65.4 (2003): 237-59.
- Burrough, P.A. "Gis and Geostatistics: Essential Partners for Spatial Analysis." Environmental Ecology and Statistics 8 (2001): 361-77.
- Cain, Jeremy, Charles Batchelor, and Dominic Waughray. "Belief Networks: A Framework for the Participatory Development of Natural Resource Management Strategies." Environment, Development and Sustainability 1 (1999): 123-33.
- Crist, Patrick J., Thomas W. Kohley, and John Oakleaf. "Assessing Land Use Impacts on Biodiversity Using an Expert Systems Tool." Landscape Ecology 15 (2000): 47-62.
- Csuti, B., and P. Crist. Methods for Developing Terrestrial Vertebrate Distribution Maps for Gap Analysis. 1998. United States Geological Survey. Available: <http://www.gap.uidaho.edu/gap/handbook/vda/index.htm>.
- Davis, C., and D. Medyckyj-Scott. "Gis Users Observed." International Journal of Geographical Information Systems 10 (1996): 363-84.



- Dymond, R. L., et al. "An Interdisciplinary Web-Enabled Sdss for Watershed Management." Journal of Water Resources Planning and Management 130.4 (2004): 290-301.
- Goodchild, M. F. "Integrating Gis and Spatial Data Analysis: Problems and Possibilities." International Journal of Geographical Information Systems 6 (1992): 407-23.
- Grado, S.C., et al. An Economic Feasibility Study for Recreational Development on the Bienville National Forest in Mississippi: Mississippi Water Resources Institute, 2002.
- Hawkins, V., and P. Selman. "Landscape Scale Planning: Exploring Alternative Land Use Scenarios." Landscape and Urban Planning 60.4 (2002): 211-24.
- Henderson, J.S., and R.W. Burn. "Uptake Pathways: The Potential of Bayesian Belief Networks to Assist the Management, Monitoring and Evaluation of Development-Oriented Research." Agricultural Systems 79 (2004): 3-15.
- Hopkins, Lewis D. "Methods for Generating Land Suitability Maps: A Comparative Evaluation." Journal of the American Institute of Planners (1977): 386-400.
- Jennings, Michael D. "Gap Analysis: Concepts, Methods, and Recent Results." Landscape Ecology 15 (2000): 5-20.
- Jennings, Michael, and J. Michael Scott. Official Description of the National Gap Analysis Program. March 1997 1997. National Gap Analysis Program. Available: <http://www.gap.uidaho.edu/about/overview/gapdescription/default.htm>. May 7, 2004.
- Joyce, James. Bayes Theorem. September 30, 2003. Available: <http://plato.stanford.edu/archives/win2003/entries/bayes-theorem2005>.
- Makropoulos, C. K., D. Butler, and C. Maksimovic. "Fuzzy Logic Spatial Decision Support System for Urban Water Management." Journal of Water Resources Planning and Management 129.1 (2003): 69-77.
- McHarg, Ian L. "Design with Nature." Ed. Natural History Press. New York, 1969.
- Mugglin, Andrew S., and Bradley P. Carlin. "Hierarchical Modeling in Geographic Information Systems: Population Interpolation over Incompatible Zones." Journal of Agricultural, Biological, and Environmental Statistics 3.2 (1998): 111-30.
- Ndubisi, Forster. "Landscape Ecological Planning." Ecological Design and Nature. Eds. George F. Thompson and Frederick R. Steiner. New York: John Wiley & Sons, Inc., 1997.

- Nijkamp, P., and H. J. Scholten. "Spatial Information Systems: Design, Modelling, and Use in Planning." International Journal of Geographical Information Systems 7 (1993): 85-96.
- Noss, Reed F. "From Plant Communities to Landscapes in Conservation Inventories: A Look at the Nature Conservancy (USA)." Biological Conservation 41 (1987): 11-37.
- Pflieger, William L. Fishes of Missouri. Jefferson City: Missouri Department of Conservation, 1975.
- Pike, William A. "Modeling Drinking Water Quality Violations with Bayesian Networks." Journal of American Water Resources Associations 40.6 (2004): 1563-78.
- Raphael, Martin G., et al. "Status and Trends of Habitats of Terrestrial Vertebrates in Relation to Land Management in the Interior Columbia River Basin." Forest Ecology and Management 153 (2001): 63-88.
- Rieman, Bruce, et al. "Evaluation of Potential Effects of Federal Land Management Alternatives on Trends of Salmonids and Their Habitats in the Interior Columbia River Basin." Forest Ecology and Management 153 (2001): 43-62.
- Robinson, Henry W., and Thomas M. Buchanan. Fishes of Arkansas. 536 vols. Fayetteville: University of Arkansas Press, 1988.
- Ross, Stephen T. Inland Fishes of Mississippi. Jackson: University Press of Mississippi, 2001.
- Sahely, Brian S. G. E., and David M. Bagley. "Diagnosing Upsets in Anaerobic Watershed Treatment Using Bayesian Belief Networks." Journal of Environmental Engineering 127.4 (2001): 302-10.
- Scott, J. Michael, et al. "Species Richness: A Geographic Approach to Protecting Biodiversity." BioScience 37 (1987): 782-88.
- . "Gap Analysis: A Geographic Approach to Protection of Biological Diversity." Wildlife Monographs 123 (1993): 41.
- Sengupta, Raja R., and David A. Bennett. "Agent-Based Modelling Environment for Spatial Decision Support." International Journal of Geographical Information Science 17.2 (2002): 157-80.
- Skidmore, Andrew, et al. "An Operational Gis Expert System for Mapping Forest Soils." Photogrammetric Engineering and Remote Sensing 62.5 (1996): 501-11.

- Spiegel, Murray R., and Larry J. Stephens. Theory and Problems of Statistics. 3rd ed. New York: McGraw-Hill, 1999.
- Spiegelhalter, David J., et al. "Bayesian Analysis in Expert Systems." Statistical Science 8.3 (1993): 219-83.
- Sprague, R. H. "A Framework for the Development of Decision Support Systems." MIS Quarterly 4 (1980): 1-25.
- Tattari, Sirkka, Titta Schultz, and Mikko Kuussaari. "Use of Belief Network Modelling to Assess the Impact of Buffer Zones on Water Protection and Biodiversity." Agriculture, Ecosystems, and Environment 96 (2003): 199-32.
- Taylor, Kerry, Gavin Walker, and Dave Abel. "A Framework for Model Integration in Spatial Decision Support Systems." International Journal of Geographical Information Science 13.6 (1999): 533-55.
- Threatened and Endangered Species System. March 30, 2005. Webpage. USGS Fish and Wildlife Service. Available: [http://ecos.fws.gov/tess\\_public/TESSWebpageUsaLists?state=MS](http://ecos.fws.gov/tess_public/TESSWebpageUsaLists?state=MS). March 30, 2005.
- Tomlin, C.D. "Introduction to Geographic Information Systems." Map Manual. New Haven, Connecticut: Yale School of Forestry and Environmental Studies, 1987.
- Varis, O. "Bayesian Decision Analysis for Environmental and Resource Management." Environmental Modelling and Software 12 (1997): 177-85.
- Vilella, Francisco J., and Rich Minnis. Gap Analysis for Conservation of Biodiversity in Mississippi. 1997. Forestry & Wildlife Research Center. Available: <http://www.cfr.msstate.edu/fwrc/wildlife/gap.htm>. May 7, 2004.
- Vilella, Fransisco. 2005. personal communication.
- Vilella, Fransisco J., et al. A Gap Analysis of Mississippi. Mississippi State University: Mississippi Cooperative Fish and Wildlife Research Unit, 2003.
- Warren, M. W., 2005. personal communication.

## **APPENDIX A**

### **HABITAT USE WEIGHTINGS**

**Appendix A.** Habitat use weightings - Probabilities of a fish using backwater (Bw), floodplain lake (Flp), riffle (rif), run and pool habitats during each life stage.

Common name	Life stages	Habitats					Comment
		Bw	Flp	Rif	Run	Pool	
threadfin shad	spawn	1	1	0	0	0.6	Pool--spawning limited to low flows, margins
	recruitment	1	1	0	0	0.6	Pool--spawning limited to low flows, margins
	ad cap	1	1	0	0.6	0.8	fish known from flowing water
blacktail shiner	spawn	0	0	1	0.5	0	fractional crevice spawner; appear flexible
	recruitment	0.8	0.8	0	1	1	occasionally in oxbows (Robinson & Buchanan)
	ad cap	0.8	0.8	0	1	1	river species; R&B report from backwaters/lakes
silverjaw minnow	spawn	0	0	1	1	0	Ross--spawn over sand; Pflieger--gravel or sandy riffles
	recruitment	0	0	1	1	1	Ross--flowing water hab
	ad cap	0	0	1	1	1	Ross--flowing water hab
clear chub	spawn	0	0	1	1	1	Ross--small streams
	recruitment	0	0	1	1	1	Ross--small streams
	ad cap	0	0	1	1	1	Ross--small streams
striped shiner	spawn	0	0	1	0	0	Gravel spawner
	recruitment	0	0	1	1	0	Flowing water, gravel bottoms
	ad cap	0	0	1	1	0	Flowing water, gravel bottoms
cherryfin shiner	spawn	1	0	0	0.5	1	Reduced currents, eddies; may have accumulation of detritus; headwater sp.
	recruitment	1	0	0	0.5	1	Reduced currents, eddies; may have accumulation of detritus; headwater sp.
	ad cap	1	0	0	0.5	1	Reduced currents, eddies; may have accumulation of detritus; headwater sp.
bluehead chub	spawn	0	0	1	0	0	Build gravel-mound nest
	recruitment	0	0	1	1	1	Flowing water, gravel/sand bottoms
	ad cap	0	0	1	1	1	Flowing water, gravel/sand bottoms
golden shiner	spawn	1	1	0	0	0.6	Pool--spawning limited to low flows, margins
	recruitment	1	1	0	0	0.6	Pool--spawning limited to low flows, margins
	ad cap	1	1	0	0	0.6	Pool--spawning limited to low flows, margins
rough shiner	spawn	0	0	1	0	0	spawns over bluehead chub nest (Ross)
	recruitment	0	0	1	1	1	Specifies pools & riffles, clean sand & gravel (Ross)
	ad cap	0	0	1	1	1	Specifies pools & riffles, clean sand & gravel (Ross)
longnose shiner	spawn	0	0	1	1	1	Flowing water, no spawning specified (Ross)
	recruitment	0	0	1	1	1	Reduced flows, sand substrate (Ross)
	ad cap	0	0	1	1	1	Reduced flows, sand substrate (Ross)
weed shiner	spawn	1	1	0	0	1	reduced or no current
	recruitment	1	1	0	0	1	reduced or no current
	ad cap	1	1	0	0	1	reduced or no current
mimic shiner	spawn	1	1	0	0	1	Spawns over veg in lakes (Black in Becker; Moyle in Ross)
	recruitment	1	1	0	1	1	Current moderate to none; moderate-size streams and oxbow lakes
	ad cap	1	1	0	1	1	Current moderate to none; moderate-size streams and oxbow lakes
pugnose minnow	spawn	1	1	0	0	1	No spawning info, except spawns under rocks (Ross)
	recruitment	1	1	0	0	1	
	ad cap	1	1	0	0	1	

## Appendix A. continued.

Common name	Life stages	Habitats					Comment
		Bw	Flp	Rif.	Run	Pool	
bullhead minnow	spawn	1	1	0	0	1	
	recruitment	1	1	0	0	1	
	ad cap	1	1	0	0	1	
creek chub	spawn	0	0	1	1	0	Gravel bottoms req'd for spawning (Robinson & Buchanan)
	recruitment	0	0	0	1	1	Do not occupy riffles)
	ad cap	0	0	0	1	1	Do not occupy riffles)
creek chubsucker	spawn	0	1	1	0	1	Pools above riffles and lakes (Ross); gravel in riffles (Robinson & Buchanan)
	recruitment	1	1	0	0	1	Clear, quiet water; over veg
	ad cap	1	1	0	0	1	Clear, quiet water; over veg
sharpfin chubsucker	spawn	1	1	1	1	1	No info, only mentioned by Ross
	recruitment	1	1	1	1	1	No info, only mentioned by Ross
	ad cap	1	1	1	1	1	No info, only mentioned by Ross
spotted sucker	spawn	0	0	1	0	0	Riffle spawner, all refs
	recruitment	1	1	0	0	1	slow water, lakes, all refs
	ad cap	1	1	0	0	1	slow water, lakes, all refs
black bullhead	spawn	1	1	0	0	1	nest in quiet waters, all refs
	recruitment	1	1	0	0	1	quiet water
	ad cap	1	1	0	0	1	quiet water
yellow bullhead	spawn	1	1	0	0	1	nest in quiet waters, all refs
	recruitment	1	1	0	0	1	quiet water
	ad cap	1	1	0	0	1	quiet water
black madtom	spawn	1	1	1	1	1	No info, only mentioned by Ross
	recruitment	0	0	0	1	1	as speckled madtom, mod current (Ross)
	ad cap	0	0	0	1	1	as speckled madtom, mod current (Ross)
tadpole madtom	spawn	1	1	0	0	1	nest in quiet waters, all refs
	recruitment	1	1	0	0	1	quiet water
	ad cap	1	1	0	0	1	quiet water
speckled madtom	spawn	1	1	0	1	1	cavity spawner (Ross)
	recruitment	0	0	0	1	1	mod current (Ross)
	ad cap	0	0	0	1	1	mod current (Ross)
freckled madtom	spawn	0	0	1	1	0	cavity spawner in current (Robinson & Buchanan; Ross)
	recruitment	0	0	1	1	1	
	ad cap	0	0	1	1	1	
pirate perch	spawn	1	1	0	0	1	eggs incubated in gills (Pflieger)
	recruitment	1	1	0	0	1	weedy pools (Ross); Avoids current (Robinson & Buchanan)
	ad cap	1	1	0	0	1	weedy pools (Ross); Avoids current (Robinson & Buchanan)
brook silverside	spawn	1	1	0	0	1	pools over aquatic veg (Robinson & Buchanan)
	recruitment	1	1	0	0	1	
	ad cap	1	1	0	0	1	

## Appendix A. continued.

Common name	Life stages	Habitats					Comment
		Bw	Flp	Rif	Run	Pool	
blackspotted topminnow	spawn	1	1	0	0	1	spawns over gravel (Ross) or, as blackstripe topminnow, over litter (Robinson & Buchanan)
	recruitment	1	1	0	0	1	
	ad cap	1	1	0	0	1	
western mosquitofish	spawn	1	1	0	0	1	
	recruitment	1	1	0	0	1	
	ad cap	1	1	0	0	1	
shadow bass	spawn	0	0	0	1	1	coarse sand or gravel, like rock bass (Ross, Robinson & Buchanan, Pfeiffer)
	recruitment	0	0.5	0	1	1	
	ad cap	0	0.5	0	1	1	
banded pygmy sunfish	spawn	1	1	0	0	1	
	recruitment	1	1	0	0	1	
	ad cap	1	1	0	0	1	
green sunfish	spawn	1	1	0	0	1	
	recruitment	1	1	0	0	1	
	ad cap	1	1	0	0	1	
warmouth	spawn	1	1	0	0	1	
	recruitment	1	1	0	0	1	
	ad cap	1	1	0	0	1	
bluegill	spawn	1	1	0	0	1	
	recruitment	1	1	0	0	1	
	ad cap	1	1	0	0	1	
dollar sunfish	spawn	1	1	0	0	1	
	recruitment	1	1	0	0	1	
	ad cap	1	1	0	0	1	
longear sunfish	spawn	1	1	0	0	1	
	recruitment	1	1	0	0	1	
	ad cap	1	1	0	0	1	
redspotted sunfish	spawn	1	1	0	0	1	only described by Ross
	recruitment	1	1	0	0	1	only described by Ross
	ad cap	1	1	0	0	1	only described by Ross
spotted bass	spawn	1	1	0	1	1	Included run because of importance of gravel/rubble
	recruitment	1	1	0	1	1	Included run because of importance of gravel/rubble
	ad cap	1	1	0	1	1	Included run because of importance of gravel/rubble
largemouth bass	spawn	1	1	0	0	1	
	recruitment	1	1	0	0	1	
	ad cap	1	1	0	0	1	
white crappie	spawn	1	1	0	0	1	
	recruitment	1	1	0	0	1	
	ad cap	1	1	0	0	1	

## Appendix A. continued.

Common name	Life stages	Habitats					Comment
		Bw	Flp	Rif	Run	Pool	
black crappie	spawn	1	1	0	0	1	
	recruitment	1	1	0	0	1	
	ad cap	1	1	0	0	1	
scaly sand darter	spawn	0	0	0	1	1	no spawning info; based on adult distrib
	recruitment	0	0	0	1	1	
	ad cap	0	0	0	1	1	
bluntnose darter	spawn	1	1	0	0.6	0.8	debris for attachment present but scarce in pools and runs
	recruitment	1	1	0	0	1	
	ad cap	1	1	0	0	1	
slough darter	spawn	1	1	0	0	1	
	recruitment	1	1	0	0	1	
	ad cap	1	1	0	0	1	
harlequin darter	spawn	0	0	1	1	1	No mention of spawning
	recruitment	0	0	1	1	1	Riffles over rough bottom in streams (Robinson & Buchanan); debris and detritus on quiet margins of pools (Pflieger)
	ad cap	0	0	1	1	1	Riffles over rough bottom in streams (Robinson & Buchanan); debris and detritus on quiet margins of pools (Pflieger)
brighteye darter	spawn	0	0	1	1	0	Ross only ref; no spawning info, based on adult distrib
	recruitment	0	0	1	1	0	only described by Ross
	ad cap	0	0	1	1	0	only described by Ross
goldstripe darter	spawn	0	0	1	1	1	no spawning info; based on adult distrib
	recruitment	0	0	1	1	1	Shallow pools (Robinson & Buchanan); 1 record in riffle below spring (Pflieger)
	ad cap	0	0	1	1	1	Shallow pools (Robinson & Buchanan); 1 record in riffle below spring (Pflieger)
speckled darter	spawn	0	0	1	0	0	Riffle spawners (Robinson & Buchanan, Ross, Pflieger)
	recruitment	0.8	0	1	1	1	Pools, occasionally riffles (Ross, Robinson & Buchanan); pools and backwaters (Pflieger)
	ad cap	0.8	0	1	1	1	Pools, occasionally riffles (Ross, Robinson & Buchanan); pools and backwaters (Pflieger)
gulf darter	spawn	0	0	1	1	0	Only in Ross
	recruitment	1	0	0	0	1	Only in Ross
	ad cap	0	0	0	1	1	Only in Ross
blackbanded darter	spawn	0	0	1	1	0	Only in Ross; over sand or gravel
	recruitment	0	0	0	1	1	Only Ross; early stages in slower flow
	ad cap	0	0	1	1	0	Only Ross; shallow riffles, but also ovr finer substrate
dusky darter	spawn	0	0	1	0	0	Riffle spawners (Robinson & Buchanan, Ross, Pflieger)
	recruitment	0.8	0	1	1	1	sandy gravel substrate, strong flow (pflieger, Robinson & Buchanan, Ross); occurs in backwaters (Pflieger)
	ad cap	0.8	0	1	1	1	sandy gravel substrate, strong flow (pflieger, Robinson & Buchanan, Ross); occurs in backwaters (Pflieger)



## **APPENDIX B**

### **QUALITY OF INFORMATION WEIGHTINGS**

**Appendix B.** Quality of information weightings - Weightings (0.9 for substantial and definitive information to 0.5 for contrasting or unstated information) depicting quality of information for backwater (Bw), floodplain lake (Flp), riffle (Rif), run and pool habitats.

Common name	Life stages	Habitats					Comment
		Bw	Flp	Rif	Run	Pool	
threadfin shad	spawn	0.9	0.9	0	0	0.9	
	recruitment	0.9	0.9	0	0	0.9	
	ad cap	0.9	0.9	0	0	0.9	
blacktail shiner	spawn	0	0	0.9	0.9	0	
	recruitment	0.9	0.9	0	0.9	0.9	
	ad cap	0.9	0.9	0	0.9	0.9	
silverjaw minnow	spawn	0	0	0.9	0.9	0	
	recruitment	0	0	0.9	0.9	0.9	
	ad cap	0	0	0.9	0.9	0.9	
clear chub	spawn	0	0	0.5	0.5	0.5	One ref (Ross, 1 paragraph)
	recruitment	0	0	0.5	0.5	0.5	One ref (Ross, 1 paragraph)
	ad cap	0	0	0.5	0.5	0.5	One ref (Ross, 1 paragraph)
striped shiner	spawn	0	0	0.9	0	0	
	recruitment	0	0	0.9	0.9	0	
	ad cap	0	0	0.9	0.9	0	
cherryfin shiner	spawn	0.5	0	0	0.5	0.5	Only general habitat info (Ross)
	recruitment	0.5	0	0	0.5	0.5	Only general habitat info (Ross)
	ad cap	0.5	0	0	0.5	0.5	Only general habitat info (Ross)
bluehead chub	spawn	0	0	0.9	0	0	
	recruitment	0	0	0.9	0.9	0.9	
	ad cap	0	0	0.9	0.9	0.9	
golden shiner	spawn	0.9	0.9	0	0	0.9	
	recruitment	0.9	0.9	0	0	0.9	
	ad cap	0.9	0.9	0	0	0.9	
rough shiner	spawn	0	0	0.9	0	0	
	recruitment	0	0	0.9	0.9	0.9	
	ad cap	0	0	0.9	0.9	0.9	
longnose shiner	spawn	0	0	0.5	0.5	0.5	Gen habitat info; no spawning info
	recruitment	0	0	0.8	0.8	0.8	Limited but definitive info in Ross
	ad cap	0	0	0.8	0.8	0.8	Limited but definitive info in Ross
weed shiner	spawn	0.5	0.5	0	0	0.5	No mention of spawning habitats
	recruitment	0.9	0.9	0	0	0.9	
	ad cap	0.9	0.9	0	0	0.9	

## Appendix B. continued.

Common name	Life stages	Habitats					Comment
		Bw	Flp	Rif	Run	Pool	
mimic shiner	spawn	0.5	0.5	0	0	0.5	Two refs for spawning, but only for lakes
	recruitment	0.9	0.9	0	0	0.9	
	ad cap	0.9	0.9	0	0	0.9	
pugnose minnow	spawn	0.6	0.6	0	0	0.6	Low prob, because rocks not congruent with pools & backwaters
	recruitment	0.9	0.9	0	0	0.9	
	ad cap	0.9	0.9	0	0	0.9	
bullhead minnow	spawn	0.9	0.9	0	0	0.9	
	recruitment	0.9	0.9	0	0	0.9	
	ad cap	0.9	0.9	0	0	0.9	
creek chub	spawn	0	0	0.9	0.9	0	
	recruitment	0	0	0	0.9	0.9	
	ad cap	0	0	0	0.9	0.9	
creek chubsucker	spawn	0	0.9	0.9	0	0.9	
	recruitment	0.9	0.9	0	0	0.9	
	ad cap	0.9	0.9	0	0	0.9	
sharpfin chubsucker	spawn	0.5	0.5	0.5	0.5	0.5	
	recruitment	0.5	0.5	0.5	0.5	0.5	
	ad cap	0.5	0.5	0.5	0.5	0.5	
spotted sucker	spawn	0	0	0.9	0	0	
	recruitment	0.9	0.9	0	0	0.9	
	ad cap	0.9	0.9	0	0	0.9	
black bullhead	spawn	0.9	0.9	0	0	0.9	
	recruitment	0.9	0.9	0	0	0.9	
	ad cap	0.9	0.9	0	0	0.9	
yellow bullhead	spawn	0.9	0.9	0	0	0.9	
	recruitment	0.9	0.9	0	0	0.9	
	ad cap	0.9	0.9	0	0	0.9	
black madtom	spawn	0.5	0.5	0.5	0.5	0.5	
	recruitment	0	0	0	0.9	0.9	
	ad cap	0	0	0	0.9	0.9	
tadpole madtom	spawn	0.9	0.9	0	0	0.9	
	recruitment	0.9	0.9	0	0	0.9	
	ad cap	0.9	0.9	0	0	0.9	

## Appendix B. continued.

Common name	Life stages	Habitats					Comment
		Bw	Flp	Rif	Run	Pool	
speckled madtom	spawn	0.7	0.7	0	0.7	0.7	do not indicate hab pref for location of cavity
	recruitment	0	0	0	0.9	0.9	
	ad cap	0	0	0	0.9	0.9	
freckled madtom	spawn	0	0	0.9	0.9	0	
	recruitment	0	0	0.9	0.9	0.9	
	ad cap	0	0	0.9	0.9	0.9	
pirate perch	spawn	0.7	0.7	0	0	0.7	do not indicate hab pref for location of cavity
	recruitment	0.9	0.9	0	0	0.9	
	ad cap	0.9	0.9	0	0	0.9	
brook silverside	spawn	0.9	0.9	0	0	0.9	
	recruitment	0.9	0.9	0	0	0.9	
	ad cap	0.9	0.9	0	0	0.9	
blackspotted topminnow	spawn	0.9	0.9	0	0	0.9	
	recruitment	0.9	0.9	0	0	0.9	
	ad cap	0.9	0.9	0	0	0.9	
western mosquitofish	spawn	0.9	0.9	0	0	0.9	
	recruitment	0.9	0.9	0	0	0.9	
	ad cap	0.9	0.9	0	0	0.9	
shadow bass	spawn	0	0	0	0.8	0.8	lowered prob because using info for rock bass
	recruitment	0	0.9	0	0.9	0.9	
	ad cap	0	0.9	0	0.9	0.9	
banded pygmy sunfish	spawn	0.9	0.9	0	0	0.9	
	recruitment	0.9	0.9	0	0	0.9	
	ad cap	0.9	0.9	0	0	0.9	
green sunfish	spawn	0.9	0.9	0	0	0.9	
	recruitment	0.9	0.9	0	0	0.9	
	ad cap	0.9	0.9	0	0	0.9	
warmouth	spawn	0.9	0.9	0	0	0.9	
	recruitment	0.9	0.9	0	0	0.9	
	ad cap	0.9	0.9	0	0	0.9	

## Appendix B. continued.

Common name	Life stages	Habitats					Comment
		Bw	Flp	Rif	Run	Pool	
bluegill	spawn	0.9	0.9	0	0	0.9	
	recruitment	0.9	0.9	0	0	0.9	
	ad cap	0.9	0.9	0	0	0.9	
dollar sunfish	spawn	0.9	0.9	0	0	0.9	
	recruitment	0.9	0.9	0	0	0.9	
	ad cap	0.9	0.9	0	0	0.9	
longear sunfish	spawn	0.9	0.9	0	0	0.9	
	recruitment	0.9	0.9	0	0	0.9	
	ad cap	0.9	0.9	0	0	0.9	
redspotted sunfish	spawn	0.9	0.9	0	0	0.9	
	recruitment	0.9	0.9	0	0	0.9	
	ad cap	0.9	0.9	0	0	0.9	
spotted bass	spawn	0.9	0.9	0	0.9	0.9	
	recruitment	0.9	0.9	0	0.9	0.9	
	ad cap	0.9	0.9	0	0.9	0.9	
largemouth bass	spawn	0.9	0.9	0	0	0.9	
	recruitment	0.9	0.9	0	0	0.9	
	ad cap	0.9	0.9	0	0	0.9	
white crappie	spawn	0.9	0.9	0	0	0.9	
	recruitment	0.9	0.9	0	0	0.9	
	ad cap	0.9	0.9	0	0	0.9	
black crappie	spawn	0.9	0.9	0	0	0.9	
	recruitment	0.9	0.9	0	0	0.9	
	ad cap	0.9	0.9	0	0	0.9	
scaly sand darter	spawn	0	0	0	0.5	0.5	
	recruitment	0	0	0	0.9	0.9	
	ad cap	0	0	0	0.9	0.9	
bluntnose darter	spawn	0.6	0.6	0	0.6	0.6	Ross, spawn on twigs or leaves
	recruitment	0.7	0.7	0	0	0.7	No mention of juvenile habits
	ad cap	0.8	0.8	0	0	0.8	Consistent--use of sluggish habitats, but no specifics
slough darter	spawn	0.9	0.9	0	0	0.9	
	recruitment	0.9	0.9	0	0	0.9	
	ad cap	0.9	0.9	0	0	0.9	

## Appendix B. continued.

Common name	Life stages	Habitats					Comment
		Bw	Flp	Rif	Run	Pool	
harlequin darter	spawn	0	0	0.5	0.5	0.5	Good but somewhat conflicting in precludes assigning weights to habitats
	recruitment	0	0	0.8	0.8	0.8	
	ad cap	0	0	0.8	0.8	0.8	
brihteye darter	spawn	0	0	0.5	0.5	0	
	recruitment	0	0	0.9	0.9	0	
	ad cap	0	0	0.9	0.9	0	
goldstripe darter	spawn	0	0	0.5	0.5	0.5	Low prob for riffle; only 1 somewhat aberant report
	recruitment	0	0	0.6	0.9	0.9	
	ad cap	0	0	0.6	0.9	0.9	
speckled darter	spawn	0	0	0.9	0	0	
	recruitment	0.9	0	0.9	0.9	0.9	
	ad cap	0.9	0	0.9	0.9	0.9	
gulf darter	spawn	0	0	0.9	0.9	0	
	recruitment	0.9	0	0	0	0.9	
	ad cap	0	0	0	0.9	0.9	
blackbanded darter	spawn	0	0	0.9	0.9	0	
	recruitment	0	0	0	0.9	0.9	
	ad cap	0	0	0.9	0.9	0	
dusky darter	spawn	0	0	0.9	0	0	
	recruitment	0.9	0	0.9	0.9	0.9	
	ad cap	0.9	0	0.9	0.9	0.9	

## **APPENDIX C**

### **FISH RANKED BY CATCH RATE.**

**Appendix C.** Fishes collected in the Leaf River and tributaries in Smith County, Mississippi, ranked by mean Catch rate.

---

<u>Species</u>	<u>Common Name</u>	<u>Catch</u>	<u>Abundant Class</u>
<i>Gambusia affinis</i>	mosquitofish	15.92	Abundant
<i>Semotilus atromaculatus</i>	creek chub	8.33	Abundant
<i>Lepomis cyanellus</i>	green sunfish	6.42	Abundant
<i>Lepomis macrochirus</i>	bluegill	6.33	Abundant
<i>Lepomis megalotis</i>	longear sunfish	5.67	Abundant
<i>Etheostoma parvipinne</i>	goldstripe darter	4.25	Abundant
<i>Fundulus olivaceus</i>	blackspotted topminnow	4.17	Abundant
<i>Lucilus chrysocephalus</i>	striped shiner	4.00	Abundant
<i>Lepomis gulosus</i>	warmouth	3.58	Abundant
<i>Hybopsis winchelli</i>	clear chub	3.42	Abundant
<i>Notemigonus crysoleucas</i>	golden shiner	3.00	Abundant
<i>Lythrurus roseipinnis</i>	cherryfin shiner	2.67	Abundant
<i>Erimyzon oblongus</i>	creek chubsucker	2.25	Abundant
<i>Etheostoma chlorosomum</i>	bluntnose darter	1.92	Common
<i>Opsopoedus emiliae</i>	pugnose minnow	1.83	Common
<i>Notropis longirostris</i>	longnose shiner	1.67	Common
<i>Nocomis leptosphalus</i>	bluehead chub	1.42	Common
<i>Lepomis miniatus</i>	redspotted sunfish	1.33	Common
<i>Etheostoma swaini</i>	gulf darter	1.33	Common
<i>Elassoma zonatum</i>	banded pygmy sunfish	1.00	Common
<i>Notropis texanus</i>	weed shiner	0.92	Common
<i>Notropis baileyi</i>	rough shiner	0.83	Common
<i>Lepomis marginatus</i>	dollar sunfish	0.75	Common
<i>Pimephales vigilax</i>	bullhead minnow	0.67	Common
<i>Cyprinella venusta</i>	blacktail shiner	0.58	Common
<i>Ameiurus natalis</i>	yellow bullhead	0.58	Common
<i>Micropterus salmoides</i>	largemouth bass	0.50	Common
<i>Etheostoma gracile</i>	slough darter	0.50	Common
<i>Ericymba buccata</i>	silverjaw minnow	0.42	Common
<i>Aphredoderus sayanus</i>	pirate perch	0.42	Common
<i>Ameiurus melas</i>	black bullhead	0.33	Common
<i>Noturus funebris</i>	black madtom	0.33	Common
<i>Micropterus punctulatus</i>	spotted bass	0.25	Common
<i>Noturus nocturnus</i>	freckled madtom	0.17	Common
<i>Etheostoma stigmaeum</i>	speckled darter	0.17	Common
<i>Minytrema melanops</i>	spotted sucker	0.08	Common
<i>Dorosoma petenense</i>	threadfin shad	0.00	Rare
<i>Notropis volucellus</i>	mimic shiner	0.00	Rare



**Appendix C. continued**

<i>Erimyzon tenuis</i>	sharpfin chubsucker	0.00	Rare
<i>Noturus gyrinus</i>	tadpole madtom	0.00	Rare
<i>Noturus leptacanthus</i>	speckled madtom	0.00	Rare
<i>Labidesthes sicculus</i>	brook silverside	0.00	Rare
<i>Ambloplites ariommus</i>	shadow bass	0.00	Rare
<i>Pomoxis annularis</i>	white crappie	0.00	Rare
<i>Pomoxis nigromaculatus</i>	black crappie	0.00	Rare
<i>Ammocryta vivax</i>	scaly sand darter	0.00	Rare
<i>Etheostoma bistris</i>	harlequin darter	0.00	Rare
<i>Etheostoma lynceum</i>	brighteye darter	0.00	Rare
<i>Percina nigrofasciata</i>	blackbanded darter	0.00	Rare
<i>Percina sciera</i>	dusky darter	0.00	Rare

## **APPENDIX D**

### **BASELINE ABUNDANCE PROBABILITIES.**

**Appendix D.** Baseline abundance probabilities for habitat conditions conducive to high success of all life stages and habitat conditions that impede all life stages. (low success of all life stages).

Abundance Class	"Best Case" Habitat Conditions				"Worst Case" Habitat Conditions			
	abundant	common	rare	absent	abundant	common	rare	absent
Abundant (General) <sup>1</sup>	90	10	0	0	5	20	70	5
Abundant (Specific) <sup>2</sup>	90	10	0	0	5	10	60	25
Common (General)	30	70	0	0	0	10	70	20
Common (Specific)	30	70	0	0	0	10	60	30
Rare	10	40	50	0	0	0	40	60

<sup>1</sup> Fishes without highly specific habitat requirements for one or more life stages.

<sup>2</sup> Fishes with a highly specific habitat requirement for one or more life stages.

## APPENDIX E

### ABUNDANCE PROBABILITIES

**Appendix E.** Abundance probabilities - Probabilities of species becoming abundant (Abu.), common (Cm.), ra., or absent (Abs.) with high and low success in all life stages.

Common name	Abundance class	High success - all life stages				Low success - all life stages				Comments
		Abu.	Cm.	Ra.	Abs.	Abu.	Cm.	Ra.	Abs.	
threadfin shad	rare	10	40	50	0	0	0	40	60	
blacktail shiner	common	30	70	0	0	0	10	70	20	
silverjaw minnow	common	30	70	0	0	0	10	70	20	
clear chub	abundance	90	10	0	0	5	20	70	5	
striped shiner	abundance	90	10	0	0	5	10	60	25	specific habitat
cherryfin shiner	abundance	90	10	0	0	5	20	70	5	
bluehead chub	common	30	70	0	0	0	10	60	30	specific habitat
golden shiner	abundance	90	10	0	0	5	10	60	25	specific habitat
rough shiner	common	30	70	0	0	0	10	60	30	specific habitat
longnose shiner	common	30	70	0	0	0	10	70	20	
weed shiner	common	30	70	0	0	0	10	70	20	
mimic shiner	rare	10	40	50	0	0	0	40	60	
pugnose minnow	common	30	70	0	0	0	10	70	20	
bullhead minnow	common	30	70	0	0	0	10	70	20	
creek chub	abundance	90	10	0	0	5	10	60	25	specific habitat
creek chubsucker	abundance	90	10	0	0	5	10	60	25	specific habitat
sharpfin chubsucker	rare	10	40	50	0	0	0	40	60	
spotted sucker	common	30	70	0	0	0	10	60	30	specific habitat
black bullhead	common	30	70	0	0	0	10	70	20	
yellow bullhead	common	30	70	0	0	0	10	70	20	
black madtom	common	30	70	0	0	0	10	70	20	
tadpole madtom	rare	10	40	50	0	0	0	40	60	
speckled madtom	rare	10	40	50	0	0	0	40	60	
freckled madtom	common	30	70	0	0	0	10	70	20	
pirate perch	common	30	70	0	0	0	10	70	20	
brook silverside	rare	10	40	50	0	0	0	40	60	
blackspotted topminnow	abundance	90	10	0	0	5	10	60	25	specific habitat
western mosquitofish	abundance	90	10	0	0	5	45	50	0	resilient
shadow bass	rare	0	40	60	0	0	0	40	60	typically low pop. numbers
banded pygmy sunfish	common	30	70	0	0	0	10	70	20	

**Appendix E. continued**

Common name	Abundance class	High success - all life stages				Low success - all life stages				Comments
		Abu.	Cm.	Ra.	Abs	Abu.	Cm.	Ra.	Abs.	
green sunfish	abundance	90	10	0	0	0	25	70	5	specific habitat
warmouth	abundance	90	10	0	0	0	25	70	5	specific habitat
bluegill	abundance	90	10	0	0	0	25	70	5	
dollar sunfish	common	30	70	0	0	0	10	70	20	
longear sunfish	abundance	90	10	0	0	0	25	70	5	specific habitat
redspotted sunfish	common	30	70	0	0	0	10	70	20	
spotted bass	common	30	70	0	0	0	10	70	20	
largemouth bass	common	30	70	0	0	0	10	70	20	
white crappie	rare	10	40	50	0	0	0	40	60	
black crappie	rare	10	40	50	0	0	0	40	60	
scaly sand darter	rare	10	40	50	0	0	0	40	60	
bluntnose darter	common	30	70	0	0	0	10	70	20	
slough darter	common	30	70	0	0	0	10	70	20	
harlequin darter	rare	10	40	50	0	0	0	40	60	
brighteye darter	rare	10	40	50	0	0	0	40	60	
goldstripe darter	abundance	90	10	0	0	5	20	70	5	
speckled darter	common	30	70	0	0	0	10	70	20	
gulf darter	common	30	70	0	0	0	10	70	20	
blackbanded darter	rare	10	40	50	0	0	0	40	60	
dusky darter	rare	10	40	50	0	0	0	40	60	

## **APPENDIX F**

### **STEPS IN THE SDSS PROCESS.**

## **Appendix F.** Steps in the SDSS process

Described in more detail in Chapter V, the following steps are the process associated with the SDSS. Steps are broken into sections pertaining to BBN, GIS, and GAP.

### **GIS -**

**Step 1:** Lake site digitization.

**Step 2:** Lake site aquatic habitat delineation.

**Step 3:** Aquatic habitat quantification.

### **BBN -**

**Step 4:** Fish survey data acquisition.

**Step 5:** Fish survey data preparation.

**Step 6:** Life stage/habitat use matrix construction.

**Step 7:** Baseline BBN model construction.

**Step 8:** Leaf River BBN model construction.

**Step 9:** Test site BBN model construction.

**Step 10:** Leaf River/test site BBN model comparison.

**Step 11:** Lake site is found acceptable.

### **GAP -**

**Step 12:** Gap Analysis Program data acquisition.

**Step 13:** GAP data preparation.

**Step 14:** Bienville National Forest and lake site subset.

**Step 15:** GAP subset calculations.

**Step 16:** GAP data analysis.